

**AGREEMENT IN NORTHERN SOTHO CONSTRUCTION:  
A MORPHOLOGICAL AND SEMANTIC STUDY**

**BY**

**THOBAKGALE JOHANNES KGANAKGA**

*Dissertation presented in partial fulfilment of the requirements*

*for the*

**DEGREE**

*of*

**MASTERS OF ARTS**

*in the*

**DISCIPLINE OF AFRICAN LANGUAGES IN THE FACULTY  
OF HUMANITIES**

*at the*

**UNIVERSITY OF THE NORTH**

**-PROMOTER: DR. M.M. SEPOTA**

**MARCH 2004**



03/35526

## TABLE OF CONTENTS

page

### CHAPTER 1. BACKGROUND TO THE PROBLEM

1.	INTRODUCTION.....	1
1.1	BACKGROUND TO THE PROBLEM.....	1
1.2	AIM OF THE STUDY.....	3
1.3	THE RATIONALE FOR THE STUDY.....	3
1.4	THE SIGNIFICANCE OF THE STUDY.....	3
1.5	METHODOLOGY.....	3
1.5.1	Qualitative research method.....	4
1.5.2	Data collection.....	5
1.5.2.1.	<i>Primary Research Techniques</i> .....	5
1.5.2.2.	<i>Secondary Research Method</i> .....	5
1.6.	LITERATURE REVIEW.....	6
1.6.2.	Louwrens (1991).....	7
1.6.3.	Poulos, et .a.l. (1994).....	8
1.6.4.	Lombard et. a.l. (1985).....	8
1.6.5.	Ziervogel (1975).....	9
1.6.6.	Kgware (1995).....	10
1.6.7.	Ntsundeni (2002).....	10
1.6.8.	Bartley Com (1999).....	11
1.6.9.	Du Plessis and Madadzhe (1999).....	13
2	<b>CHAPTER 2. THE USE OF NOUN CLASSES IN AGREEMENT</b>	
2.1	INTRODUCTION.....	16
2.2	Definition of concepts.....	16
2.2.1	Noun classes.....	16
2.2.2	Strong concordial agreements.....	16
2.2.3	Weak concordial agreements.....	17

2.3	TYPES AND STRUCTURE OF NOUN CLASSES AND CONCORDS.....	19
2.3.1	Strong concordial agreement.....	21
2.4.	ABSOLUTE PRONOUNS.....	26
2.4.1	Weak concordial agreements.....	30
2.5	SYNTACTIC CHARACTERISTICS OF AGREEMENT.....	33
2.5.1	Agreement appearing with noun phrase.....	33
2.5.2	Agreement appearing on subject position.....	34
2.5.3	Agreement appearing in the middle of the sentence.....	34
2.5.4	Agreement appearing in the place of the noun phrase.....	35
2.5.5	Agreement appearing with absolute pronoun.....	35
2.5.6	Agreement appearing with pronoun and noun phrase.....	36
2.5.7	Agreement appearing with compound nouns.....	37
2.5.8	Agreement with a list of different races.....	37
2.6	CONCLUSION.....	38

### **CHAPTER 3. NOTIONAL AGREEMENT IN NORTHERN SOTHO CONSTRUCTION**

3.1	INTRODUCTION.....	40
3.2	DEFINITION AND STRUCTURE OF NOTIONAL AGREEMENT.....	40
3.3	CATEGORIES INTO WHICH NOTIONAL AGREEMENT ARE FOUND.....	42
3.3.1	The agreement noun phrases that are introduced in plural forms give a singular meaning.....	43
3.3.2	Noun phrases that belong to class 9 represent singular form but use agreement with plural meaning.....	45
3.3.3	Noun phrases that represent liquid mass do not have singular form but have singular agreement / meaning.....	48
3.3.4	Huge and immense noun phrases using singular	

3.3.4	Huge and immense noun phrases using singular agreement.....	50
3.3.5	Abstract noun always take singular agreement / meaning.....	51
3.3.6	Names of organisations, institutions, clubs, Co-operations using singular agreement.....	52
3.3.7	Honorific take plural concordial agreement.....	54
3.3.8	Questions directed to respected people use the <u>le</u> agreement.....	55
3.3.9	Honorific agreement to address strangers.....	56
3.3.10	The use of agreement which refer to objects and animals.....	58
3.3.11	Agreement referring to human being with unbecoming manners...	59
3.3.12	Agreement referring to people with some expertise in some fields...	61
3.4	CONCLUSION.....	62

## CHAPTER 4. THE MORPHOLOGICAL STRUCTURE OF AGREEMENT

4.1	INTRODUCTION.....	63
4.2	DEFINITION OF CONCEPTS.....	63
4.2.1.	Morphology.....	63
4.3	HOW AGREEMENT IS TREATED IN SYNTAX.....	64
4.3.1	INFLECTION.....	65
4.3.1.1.	<i>Agreement</i> .....	65
4.3.1.2.	<i>Subjectival agreement</i> .....	66
4.3.1.3.	<i>Grammatical agreement</i> .....	71
4.3.1.4.	<i>Objectival agreement</i> .....	73
4.3.1.5.	<i>The objectival agreement 1<sup>st</sup> person plural</i> .....	84
4.3.1.6.	<i>Subjectival agreement for noun class 1a and 2a</i> .....	85
4.3.1.7.	<i>Objectival agreement for noun class 1a and 2a</i> .....	86
4.3.1.8.	<i>Demonstratives</i> .....	88
4.3.1.9.	<i>Concordial elements and their class prefixes</i> .....	90
4.4.	DISTRIBUTION OF AGREEMENT MORPHEMES.....	93
4.4.1	Pronouns.....	94

4.4.1.1	<i>Absolute pronouns</i> .....	95
4.4.1.2	<i>Possessive pronouns</i> .....	99
4.4.1.3	<i>Quantitative pronouns</i> .....	101
4.5	AGREEMENT BY PROXIMITY.....	103
4.6	CONCLUSION.....	105

## **CHAPTER 5. CONCLUSION**

5.1.	THE CONCLUSION.....	106
5.2.	BIBLIOGRAPHY.....	110

(i)

**DECLARATION**

I, the undersigned, hereby declare that the work contained in this dissertation, entitled **Agreement in Northern Sotho construction: A morphological and semantic study** and all the associated references is my own original work, and that I have not previously submitted it in any form whatsoever, to any university or any other educational institution for any degree or educational purpose.



SIGNATURE

25/03/2004  
DATE

( ii )

### **DEDICATION**

I am proud to dedicate this dissertation to my beautiful and carrying wife Kgabo Lydia, my first born daughter Mokgadi, and son Masilo Archie.

I would like also to thank my mother Kgabo Josphine, and my father Motlatjo David, who played a major role in making me, who I am today.

## ACKNOWLEDGEMENTS

I feel the need to mention that alone I could not have made this work a success. The support and the guidance of a number of knowledgeable and skilful persons were necessary. One man cannot achieve the work of this nature without assistance: Seema sa sepedi se re : **mphiri o tee ga o lle.**

Among individuals who played a role in assisting me in making this work a success I have to mention is my supervisor, Dr. M. M Sepota, who guided me during the course of this study. When I encountered problems he was always there as a source and guide. I will always remember his patience in encouraging and motivating me all the time when I lost hope. It was such a pleasure to work and be guided by such a knowledgeable and skilful person. To him, I say: "Your boldness, which embodies simplicity, kindness and dedication, made this happen. I would like to thank you, Doctor!"

I also wish to extend a special word of gratitude to Professor N. R. Madadzhe, who coordinates Masters degree programmes in African Languages at the university for supporting the students in this department. To this great man, I say: " God be with you, Prof, you are indeed a born leader."

My heartfelt gratitude is also directed to my church elder C. G. Meso and his wife Monica who informed me of an opportunity of studying for a Masters of Arts degree and encouraged me to enrol for this degree. Elder Meso became my colleague in the Masters class and he used to assist me in writing assignments and essays during the course of my study.



I wish to thank my dear wife Kgabo Lydia whole-heartedly. She has been an inspiration to me, and she assisted me in assembling relevant materials to complete this report, and also helped in the typing of the report. I also thank her for being next to me whenever I lost hope.

I would like to thank Mrs T. M. Matla-my lecturer for she was also an outstanding source of encouragement. She constantly reminded me that I was capable and would be successful. Her noble words uplifted my spirit to go up whenever tough times came.

More than any other person, I would like to thank the ALMIGHTY GOD for giving me life and strength to carry on with this research up to the end. For without His Mercy and Grace I would not have completed this dissertation.

**ABSTRACT**

This study explores Agreement in Northern Sotho construction and how it manifests itself through various forms and semantic value.

**Chapter 1** deals with background to the problem, the aim of the study, the rationale for the study, the significance of the study , methodology and literature review.

**Chapter 2** deals with the use of noun classes in agreement, the types and structure of noun classes and concords, differences between strong and weak concordial agreements and the use of absolute pronouns with agreements, and semantic characteristics of agreement in sentences.

**Chapter 3** treats the issue of Notional agreement in Northern Sotho construction. The discussion dwells mainly on singular noun with plural agreements or plural noun with singular agreement. This section researches the influence of agreement on a sentence. Ample examples have being provided to illustrate various forms of agreement.

**Chapter 4** examines the morphological structure of the agreement in various forms such as how it is treated in syntax subjectively and objectively; concord; origin of agreement on noun, grammatical agreement and how inflection affects agreement, and agreement by proximity and distribution of agreement morphemes. This chapter also deals with agreement in noun classes 1a and 2a, and first and second person.

**Chapter 5** is the concluding chapter of the study followed by bibliography.

## CHAPTER 1

### 1. INTRODUCTION

#### 1.1. BACKGROUND TO THE PROBLEM

Language is a tool by which human beings can communicate their ideas, feelings, opinions and their experiences with each other. As a result, one must be careful as to what type of words or phrases to use. It is disheartening to realise that in everyday communication some Northern Sotho speakers do not take this seriously.

The South African Constitution recognises eleven languages as being official. The problem regarding the wholesome acceptance and usage of some of these languages lies in the fact that they are regarded as being underdeveloped. As a result of this, these languages are not respected, developed and remain marginalised.

Some of the non-Northern Sotho speakers, at times find themselves in trouble with the language speakers in that they use it without following correct grammatical rules. This may end up bringing some misunderstandings. For instance, the same can be observed in the following incorrectly constructed sentence.

1. Mosotho e nwa “bier” letšatši ka moka.  
(A Blackman (it) drinks beer the whole day.)

A sentence constructed like the one above, is likely to be interpreted as indicating that the speaker does not respect black people. The concordial agreement *e* used in the sentence above, comes from Class Noun 9. The contents of Class Noun 9 refers to names of objects and animals, and not human beings. The following sentences are good examples for the use of concordial agreement *e* for Class Noun 9.

## Noun class 9

## subject concord

-

e

Examples:

2. Nku e fula bjang.  
( The sheep grazes grass.)
3. Koloji e robegile maabane.  
( The car had breakdown yesterday.)
4. Mpša e phela ka nama.  
( Dog lives on meat.)

Sentence 1 above might be interpreted as though the dignity of a black man is being reduced to that of an animal or an object. Such misunderstandings, if not carefully addressed, may result in serious unnecessary conflicts between different racial groups, especially during this period of radical tensions in a new political period. Another important section to be researched in Northern Sotho is notional agreement. In notional agreement, the agreement is carried in the meaning of sentence and not in the sentence structure. The subject of the sentence may appear in plural form but the subject concord in singular form. Such constructions are not common in Northern Sotho and need to be explored.

Notable examples are such as the following:

5. Dikete tše lesome ke tšhelete ye ntši.  
(Ten thousand bucks is a lot of money.)
6. Bohle ba ile toropong.  
(Everyone has gone to town.)

## **1.2. THE AIM OF THE STUDY**

The aim of this study is to examine agreement in Northern Sotho construction. In order to accomplish this task, the following questions will be answered.

- ❖ How do we use concordial agreement?
- ❖ What is the morphological structure of concords?
- ❖ How many types of agreement occur in Northern Sotho?

## **1.3. THE RATIONALE FOR THE STUDY**

It is important that this study is conducted because after its completion it will help non-Northern Sotho speakers to have the knowledge and better understanding of how to use concordial agreement in Northern Sotho. It will also lay a foundation for further research in this field.

## **1.4. THE SIGNIFICANCE OF THE STUDY**

The study will also serve a springboard for further research on the concept of agreement in African languages, a necessary investigation if we are to develop these languages.

## **1.5. METHODOLOGY**

The nature of a research methodology is of the most vital importance for a research project. Before embarking on a research project, a researcher has the task of selecting relevant research methods for his or her problem.

### 1.5.1. Qualitative research method

The qualitative approach will be used in this study in order for the researcher to understand the issue of using appropriate concordial agreement in constructing Northern Sotho sentences, and to address some of the problems Northern Sotho speakers might encounter when using concordial morphemes.

Qualitative research method refers to the collection and analysis of data in order to gain insight into the situation of interest. Creswell (1994:2) regards qualitative research as an inquiry process of understanding a social human problem, based on building a complex, holistic picture, formed with words, reporting detailed views of informants, and conducted in natural setting.

In accordance with the definition laid down by Creswell, it is clear that the qualitative method is relevant to this study as it will assist the researcher in completing this proposal in the study of agreement in Northern Sotho.

The comparative research method, which falls within the qualitative research method will also be used in this study. Its importance is based on the fact that it compares or contrasts two or more things in order to see the similarities or differences in terms of size, colour, usage, mode, etc. Ragin ( 1987: 2 ) states :

Comparative method is typically used in a narrow sense to refer to a specific kind of comparison—the comparison of large macro social units. The comparative method traditionally has been treated as the core method of comparative social science, the branch of social science concerned with cross-societal differences and similarities.

This approach is also suitable in this study as it will be used to compare different uses of agreement in Northern Sotho constructions.

### 1.5.2. Data collection

The most essential feature of a research is the collection of information(data). Research basically involves investigation and collection of such information for use during the research project. In collecting data during the research, the researcher intends to employ the following techniques:

#### *1.5.1.1. Primary Research Technique*

The primary method is a method whereby first-hand information is obtained from the respondents. This may be achieved by interviews. During this research technique, important people such as teachers who teach Northern Sotho in institutions of higher learning such as professors, doctors, high school teachers, scholars and lecturers will be consulted to gather information. Unstructured interviews will be used to get information.

#### *1.5.1.2. Secondary Research Method*

The secondary research method will also be employed in this study as this technique helps the researcher to establish, as accurately as possible, the importance and relevance of the subject i.e., matter already used by a variety of scholars. This method entails the collection of data from articles, library books, newspapers, magazines, thesis and dissertations.

## 1.6. LITERATURE REVIEW

The aim of this subsection is to analyse some of the view points of other writers on agreement in Northern Sotho construction . It is important for the researcher to go through the works of other scholars who wrote on the same topic, in order to see how they tackled agreement. The review will focus on the works of the following scholars:

- 1.6.1. Louwrens L. J ( 1991 );
- 1.6.2. Poulos , et al. ( 1994 );
- 1.6.3. Lombard , et al. ( 1985 );
- 1.6.4. Ziervogel ( 1979 );
- 1.6.5. Kgware ( 1975 );
- 1.6.6. Ntsundeni ( 2002 );
- 1.6.7. Bartley. Com ( 1996 ); and
- 1.6.8. Du Plessis J. A and Madadzhe R. N ( 1999 )

Thus far, very few scholars have attempted to undertake a study on agreement in Northern Sotho. Among those who have attempted to do so are Lombard, et al. (1985), Ziervogel (1979), Louwrens (1991), and Poulos et al. (1994). However, other scholars who attempted to deal with this topic, have not specifically focused on agreement, but have touched on it in passing as they discussed certain aspects of their research. As a result, no in-depth study was ever conducted on agreement in Northern Sotho, hence the necessity for this research. In other languages such as Tshivenda, Setswana and English, thus have been done.



### 1.6.1. Louwrens ( 1991 )

Louwrens ( 1991:13 ), in his study on concordial agreement, does not fully define agreement in Northern Sotho, but he explains the two different types of subjects and their functions in Northern Sotho, namely grammatical subject and the semantic subject. He explains that the subject agrees with the verb by means of the subject concord. He gives the examples such as the following:

7. Pula e nele maabane.  
(It rained yesterday.)
8. Letšatši le a fiša.  
(It is hot.)

Louwrens (1991) further explains that the semantic subject is a noun which refers to the agent, which is responsible for the carrying out of the action expressed by the verb. He gives examples like the following:

9. Dijo di apewa ke mosadi.  
(Food is cooked by a woman.)
10. Go bogola mpša.  
(There is a dog barking. )

He explains concordial agreement in Northern Sotho briefly. This leaves much chance for other researchers to conduct a study in this field. He does not say anything about the structure and significance of concordial agreement and their effects to Northern Sotho constructions.

### 1.6.2. Poulos et al. (1994)

In their study, Poulos et al.(1994) do not fully discuss agreement in Northern Sotho, but they give types of concords and their variant forms. They show how subject concords correspond with their noun class prefixes. The following are some examples of their subject concords and their noun classes:

	<b>Noun classes</b>	<b>Subject concords</b>
1.	<b>Mo-</b>	<b>o-</b>
	Mosadi <b>o</b> apea dijo. ( A woman cooks food.)	
2.	<b>Ba-</b>	<b>b-</b>
	Basadi <b>ba</b> _apea dijo. ( Women cook food.)	

Although these scholars have deliberated on subject concords in Northern Sotho, they nonetheless did not conduct a detailed study on agreement in Northern Sotho constructions.

### 1.6.3. Lombard et al (1985)

Another study on concordial morphemes was conducted by Lombard et al (1985:54). They briefly explained that concordial agreement are morphemes by which other words in the sentence agree with their subject nouns. They provided the following examples:

### Subject concord

11. Lesogana le bea kuranta fase.  
(The young man puts the newspaper down.)

### Object concord

12. (Bana) ke a **ba** ruta.  
(I teach them [ children].)

Lombard et al. (1985) conducted a general study on concords and did not specify their argument on agreement in Northern Sotho constructions.

#### 1.6.4. Ziervogel (1979)

Ziervogel (1979 : 18-19) attempted a study on concordial agreement by representing class nouns and their subject and object concords on a tabular form. The following are a few of his examples:

Noun classes	Subject concords
Mo-(person)	Mo,
Le-	le,
Ba-	ba,

Noun classes	Object concords
Mo-(me-)	o,
Ba -	Ba,
Go-	go,

Ziervogel (1979) maintains that the object concord, like the subject concord, brings agreement between the noun and the verb, and that these concords originate from their class prefixes. In his elaboration, Ziervogel (1979) tabulated noun prefixes and their subject and object concords, without showing their morphological structure and their significance on Northern Sotho constructions.

#### 1.6.5. Kgware (1975)

He studied predicative in Tswana. In his work, he happened to touch little on subjectival concords. He indicated that subject and object verbal concords serve as links between the subject stem and substantives. He further explained that a verb stem cannot work without agreement, except in the imperative mood. However, Kgware was not able to give a detailed morphological structure of concordial agreement and its significance on Northern Sotho constructions and thus leaving chance for the researcher to make a detailed study on Northern Sotho agreement.

#### 1.6.6. Ntsundeni (2002)

Ntsundeni (2002) conducted a study on the aspect of morpheme in Tshivenda. In his study, he happened to refer to agreement. He touched on concords and indicated that concords serve as links between other words and nouns. He gave examples in Tshivenda as follows:

13. Phulu dzi a lima.  
(The oxen are ploughing.)
  
14. Kholomo dzi a vhu hazhi.  
(The cattle are grazing them [grass].)

Ntsundeni (2002) concentrated on the general aspect of morpheme and did not elaborate on concordial agreement.

He does not show the morphology of concords and their usage on Northern Sotho construction or any of the African languages.

#### 1.6.7. **Bartley (1996)**

Bartley's practical and authoritative guide to contemporary English (1996) discusses the subject and verbal agreement in grammatical agreement, notional agreement, agreement by proximity and compound subject.

- **Grammatical agreement**

Grammatical agreement explains that the verb has the potentiality to agree with the subject in person and in number. This means that singular subjects take singular verbs while plural subjects take plural verbs. The following are good illustrations:

#### **Singular subject with singular verb**

15. Peter **goes** to town.  
(Peter o ya toropong.)

#### **Plural subjects with plural verb**

16. Peter and Mary **go** to town.  
(Peter le Maria ba ya toropong.)

- **Notional agreement (agreement in meaning)**

Notional agreement refers to agreement in which relationship between subject of the sentence and the verb is carried by the meaning of the whole sentence itself and not by the form and the tense of the verb. This aspect poses a problem when English sentences are translated into Northern Sotho. The reason behind this problem is that English sentences may take plural subjects with singular verbs but that is not the case with Northern Sotho. The following are some such examples:

17. Everyone has gone to town.  
(Bohle ba ile toropong.)
18. Ten thousand bucks is a lot of money.  
(Dikete tše lesome ke tšhelete ye ntši.)

- **Compound subjects**

In English, a compound subject connected by conjunction, normally takes a plural verb. This is also the case in Northern Sotho because, in Northern Sotho construction, compound subjects connected by *le* also take a plural verb. Some examples are the following:

19. Rebecca and Martha dance together.  
(Rebecca le Martha ba bina gotee.)

Some compound subjects are governed by a sense of unity, but the verb takes a singular form.  
Example:

20. My name and address is printed on the box.  
(Leina la ka le aterese di ngwadilwe lepokisaneng.)

There is no pure and direct translation from English sentences to Northern Sotho sentences, as a result, Northern Sotho sentences will remain with plural verbs for as long as subjects are compounded.

- **Agreement by proximity.**

Here noun which is adjacent to the verb can exert more influence than the noun that is the actual grammatical subject, to agree with the verb that is closer. This situation also applies in Northern Sotho because subjects that are closer to the verb have a greater influence on the verb than those subjects which are far from the verb. The following is an example in this regard:

21. Either John or his brothers are bringing the papers.  
(E ka ba John goba bagolo ba gagwe bao ba tlišago dipampiri.)

Although Bartley (1996) conducted a profound study on agreement in four different categories however, in English he has not given all the details of agreement such as significance in morphology, and their relationship with their class prefixes, thus, leaving much work for the researcher to conduct and outstanding study on the Northern Sotho agreement.

#### 1.6.8. **Du Plessis and Madadzhe (1999)**

In their study of Venda morphology, Du Plessis and Madadzhe focused on subjectival agreement. They divided subjectival agreement into A and B groups. Group A indicates both Agrs that appears in the present and future tenses while group B shows Agrs that are used in the perfect tense and consecutive. The latter is derived from subjectival agreement A.

The following are examples of the subjectival agreement for group A in Tshivenda morphology:

### Subjectival agreement A

Noun class	Noun prefix	Noun	Agreement
1	Mu-	Muthu	U
2	Vha-	Vhathu	Vha
3	Mu-	Muri	U
4	Mi-	Miri	I
5	Li-	Liivha	Li
6	Ma-	Maivha	A
7	Tshi-	Tshidulo	Tshi
8	Zwe-	Zwedulo	Zwe

### Subjectival agreement B

As mentioned above, subjectival agreement B is derived from subjectival agreement A. Agreement B consists of the consonant from agreement morphemes A, or a semi-vowel in the case of vowel agreement morphemes. The example of a summary of subjectival agreement B in Venda may be tabulated as follows:



Noun class	Noun prefix	Formation of agreement		Agreement
		Indicative	Consecutive	
1 person singular		ndi+o>ndo	ndi+a>nda	nd-
1 person plural		ri+o>ro	ri+a>ra	r-
2 person singular		u+o>wo	u+a>wa	w-
2 person plural		ni+o>no	ni+a>na	n-
2	Vha-	vha+o>vho	vha+a>vha	vh-
3	mu-	u+o>wo	u+a>wa	w-
4	mi-	i+o>yo	i+a>ya	y-
5	li-	li+o>lo	li+a>la	l-

From the brief analysis above, it is evident that little work has been done on the topic under discussion in Northern Sotho. This study on agreement in Northern Sotho constructions, will be endeavour to fill the gap that exists in as far as this aspect is concerned. Even if focus will be on the morphological and semantic of agreement, reference will also be made to its syntactic nature.

## **CHAPTER 2**

### **THE USE OF NOUN CLASSES IN AGREEMENT**

#### **2.1. INTRODUCTION**

The purpose of this chapter is to examine the role that noun classes play on agreement in Northern Sotho constructions. Focus will be given to the so called strong and weak concordial agreements. The distribution of agreement will concentrate on subjectival agreements .

This chapter will, therefore, endeavour to show how noun classes are involved in bringing about agreement in Northern Sotho sentences .

#### **2.2. DEFINITION OF CONCEPTS:**

##### **2.2.1. Noun classes :**

According to Lombard et al.(1985:29) noun classes are distinguished word categories into which words are classified and allocated a number to every class.

##### **2.2.2. Strong concordial agreements:**

Strong concordial agreements, refer to those concords which have more morphological resemblances to their noun prefixes. Fowler (1980:1255) Defines the term strong as: having property in a high degree of a largely or greatly impregnated with resemblance or characteristics of their producers.

In simple terms it means that strong concordial agreements share the same morphological structure with the class prefixes of those noun classes they belong to viz,

<b>Noun class</b>	<b>Noun prefix</b>	<b>Subject concord</b>
2	Ba-	ba
5	Le-	le
7	Se-	se

Let us consider the following examples:

22. **Batho ba a bolela**  
(People are speaking.)

23. **Letšatši le a fiša.**  
(The sun is hot.)

24. **Sehlare se a baba.**  
(The medicine is bitter.)

### 2.2.3. **Weak concordial agreements:**

Fowler (1980:1272) defines weak as something having less than the full or proper amount of a specific ingredient.

In other words, the morphological structure of weak concordial agreement does not exactly look the same as the noun prefixes of the noun classes to which they belong, such as those on the table below.

<b>Noun class</b>	<b>Noun prefix</b>	<b>Subject concord</b>
1	Mo-	o
3	Mo-	o
4	Me-	e
6	Ma-	a

As regards agreement, Ziervogel (1972:4) has this to say:

It is a concord which is employed in the construction of the sentence to link noun phrases and other parts of the sentence.

On the other hand, Webster's Dictionary of English Usage (1994:51) defines agreement as :

Either the agreement in number between the subject and verb of a sentence, or to the agreement in number between a pronoun and its antecedent .

Webster's New International Dictionary volume (1995 :151), supports the above definition with the following statement :

Agreement refers to formal correspondence of one word with other of one word with others in respect of inflectional gender, number case or person.

With regard to the above definitions, on agreement, it is important to note that Ziervogel (1972:4) emphasises the importance of agreement or concord as a linking agent between noun phrase and other parts of the sentence. On the other hand, Webster's definition like that of Ziervogel, puts emphasis on the use of a concord as a word in a sentence that brings agreement between one word and others. The above definitions can be summarised by one simple statement which says that agreement is a word that brings grammatical link between the subject of the sentence and the verbal phrase in the sentence. Examples:

25. Monna o nwa bjalwa.  
(The man is drinking beer).

### 2.3. TYPES AND STRUCTURE OF NOUN CLASSES AND CONCORDS:

In Northern Sotho, nouns belong to particular noun classes. Each noun consists of two parts, viz prefixes and their stems. Examples of such prefixes and stems can be illustrated, as follows:

CLASSES NOUN	PREFIX	STEM	EXAMPLES
1	Mo-	-tho	Motho .
1a	-	Matome	Matome .
2	Mo-	-hlare	Mohlare .
2a	Bo-	-Matome	BoMatome .
3	Mo-	-hlare	Mohlare .
4	Me-	-hlare	Mehlare .
5	Le-	-tšatši	Letšatši.
6	Ma-	-tšatši	Matšatši.
7	Se-	-lepe	Selepe .
8	Di-	-lepe	Dilepe .
9	N-	-ko	Nko .
10	Di-	-nko	Dinko .
14	Bo-	-hlale	Bohlale .
15	Go-	-rema	Gorema .
16	Fa-	-se	Fase .
17	Go-	-dimo	Godimo .
18	Mo-	-rago	Morago .

According to Lombard et al. (1985:30) noun classes which occur in Northern Sotho are arranged according to a recognised number and the prefix of that noun to which they belong.

These noun classes are numbered for the purpose of international recognition. According to Poulos et al. (1994:13) noun classes are in semantic content and certain generalisations can be made about the significance of each of the noun classes.

Lombard et al. (1985:29) argue that noun classes acquire international recognition and that nouns are therefore numbered to indicate the classes to which each noun belongs. As a result each noun belongs to a particular noun class. This enables scholars to study noun classes and related topics without any difficulty. The following is a Northern Sotho table for noun classes, noun prefixes, concordial agreements, and their examples.

Noun classes	Classes Prefixes	Examples	Concordial Agreement
1.	Mo-	Mosadi	O
1a	-	Tate	O
2.	Ba-	Basadi	Ba
2a.	Bo-	Botate	Ba
3.	Mo-	Mohlare	O
4	Me-	Mehlare	O
5	Le-	Letšatši	Le
6	Ma-	Matšatši	A
7	Se-	Selepe	Se
8	Di-	Dilepe	Di
9	N-	Nko	e
10	Di-	Dinko	Di
14	Bo-	Bohlale	Bo
15	Go-	Goroma	Go
16	Fa-	Fase	Go
17	Go-	Godimo	Go
18	Mo-	Morago	Go

Noun classes can be grouped according to strong and weak concordial agreements.

### 2.3.1. Strong concordial agreement

The aim of this subsection is to discuss those concordial agreements which have a strong resemblance to their noun prefixes, and to represent them on a table. Only those noun classes with similar class prefixes and concordial agreements will be discussed in this subsection.

Strong concordial agreement means that noun prefixes are duplicating themselves on subjectival agreements in terms of morphological structure.

Noun classes	Noun Prefixes	Concordial Agreement	Examples
2	Ba-	ba	Banna
5	Le-	le	Lesogana
7	Se-	Se	Selemo
8	Di-	di	Dilepe
10	Di-	di	Dikolobe
14	Bo-	bo	Bohloko
15	Go-	go	Go bolela
17	Go-	go	Godimo

The table above represents noun classes with strong concordial agreements. In this table, subject concords and noun prefixes have the same morphological characteristics.

#### NOUN CLASS 2

This is a noun class for persons. It represents personal nouns in plural form. Nouns from this class are characterised by the noun prefix **Ba-**.

The concordial agreement for this noun class remains **ba** as its noun prefix. Below are some examples to illustrate the strong correlation between noun prefixes and their concordial agreement:

26. **Bana ba** raloka gotee .  
(Children play together.)
27. **Banna ba** rwele thata .  
(Men are carrying a pole.)

### **NOUN CLASS 5**

This noun class represents both objects and living things, human beings included. The noun prefix for this class is **Le-** and its concordial agreement is **le** as well. There is a direct duplication of the noun prefix and the concordial agreement. There is, therefore a strong resemblance between the noun prefix for class 5 and its concordial agreements. The following are examples in this regard:

28. **Lesogana le** rekile sefatanaga .  
(The young man bought a car.)
29. **Leswika le** wele thabeng .  
(The rock fell from the mountain.)

### **NOUN CLASS 7**

All names in this class take the noun prefix **Se-**. It is a noun class for objects and natural phenomena.



The concordial agreements of all names and nouns that belong to this class remain **se**, as the noun prefix for this class. This class represents nouns in their singular form. Below are some of the examples in which the noun prefix and the agreement are similar.

30.       **Selepe se remile mohlare.**  
            (An axe chopped the tree.)
31.       **Sefatanaga se amega kotsing .**  
            (The car gets involved in an accident.)
32.       **Sefako se nele bošego.**  
            (Hail fell last night.)

#### **NOUN CLASS 8**

This noun class takes the noun prefix **Di-**. It is a class of objects and things in their plural form and not for human beings. The concordial agreements for this class, like the noun prefixes, represent things in their plurality. The concordial agreement is **di**. The following are examples of constructions of noun class 8:

33.       **Dilepe di rema mehlare .**  
            (Axes are chopping trees.)
34.       **Dinepe di botse .**  
            (Photographs are beautiful.)

## NOUN CLASS 10

This noun class takes the prefix **Di-**. It is a class for things and animals. All nouns in this class have **Di-** as their prefixes. The concordial agreement **di**, in this noun class takes the form of the noun prefix. The following are examples:

35. **Dinku di** fula bjang.  
(Sheep graze lawn.)
36. **Diphefo di** foka lewatle .  
(Winds blow over oceans.)

## NOUN CLASS 14

Noun class 14 represents names of natural phenomena and human situations. The noun prefix is **BO-** and the concordial agreement is **bo**. There is a direct correspondence between noun prefix and concordial agreement in constructed sentences in terms of form and structure. The following are some constructed sentences in which both the noun prefixes and the agreement are the same:

37. **Bogole bo** bohloko.  
(Disability is painful.)
38. **Boroko bo** bose .  
(Sleeping is enjoyable.)

39. **Bohodu bo a lapiša.**  
(Theft is tiresome.)

### **NOUN CLASS 15**

Noun class 15 represents processes and conditions. The noun prefix for this class is **Go-**. It is prefixed to verb stems to form nouns. The concordial agreement of this class, like the prefix, is **go**. Examples are the following constructions .

40. **Go bolela maaka go hiola mathata .**  
(Speaking lairs causes problems.)
41. **Go ngwala go kaone .**  
(Writing is better.)
42. **Go ja go phala go nwa.**  
(Eating is better than drinking.)

### **NOUN CLASS 17**

This is a class for locative nouns. The prefix in this class is **Go-** and the concordial agreements is also **go**. Both class prefix and the concordial agreement have similar morphological structures. The following are examples:

43. **Go ya godimo go thata go fihla, ge o tšwafa.**  
(Going up is difficult when you are lazy.)

Sentences 26 to 43 above, show that in each case concordial agreements and noun prefixes share similar characteristics. It means that noun prefixes repeat themselves as concordial agreements. Such a relationship makes concordial agreements to be strong with their noun prefixes.

#### **2.4. ABSOLUTE PRONOUNS**

The use of absolute pronouns on any sentence construction does not affect the type of concordial agreements of a given noun class. Absolute pronouns used, may have the consonant of the noun prefix of that noun class without it being totally changed, with the exception of class nouns 8 and 10.

When nouns are left out in a sentence, and pronouns are used in their place, the following constructions 44, 45 and 46 will result. Such will show relationship between the absolute pronoun and concordial agreement.

##### **NOUN CLASS 2**

44.        **Bona ba** raloka kgwele ya maoto.  
              (They are playing soccer.)

##### **NOUN CLASS 5**

45.        **Lona le** nyetše mosadi.  
              (He married a woman.)

## **NOUN CLASS 7**

46.      **Sona se rema mehlare.**  
            (It is chopping trees.)

## **NOUN CLASS 8**

47.      **Tšona di rema mehlare.**  
            (They are chopping trees.)

## **NOUN CLASS 10**

48.      **Tšona di fula bjang.**  
            (They graze lawn.)

## **NOUN CLASS 14**

49.      **Gona go bothata go namelela.**  
            (It is difficult to ascend.)

The **go** in sentence 49 above is the concordial agreement and it is similar to a noun prefix in that sentence. The **go** can appear in the sentence without the absolute pronoun. In other words, the **go** can also serve as a pronoun in that sentence. In this case the sentence will read as follows:

50. **Go bothata go namela.**  
(Is difficult to ascend.)

### **NOUN CLASS 15**

51. **Gona go hlolela batho mathata.**  
(It causes people some problems.)

In the above sentences, 45 to 51, in the noun classes mentioned, noun phrases are substituted by pronouns, but a concordial agreement such as **le**, **se**, **di**, and **go** still looks exactly the same as the noun prefix of that noun class. This situation occurs with strong concordial morphemes.

### **NOUN CLASS 1a and 2a**

Different from the rest of the noun classes mentioned above, are noun classes **1a** and **2a**. These noun classes represent personal nouns (names). Noun class **1a** represents all personal names or nouns in singular form. The noun class **1a** does not have a particular noun class prefix as personal names take different letters of alphabet. Such personal names can be illustrated as follows: Aphane, Kgware, Molatelo, Johanna, Mashudu, etc. The concordial agreements in this noun class, remains **o**. All names in class **1a** take **o** as a concordial agreement. The reason for the use of concordial agreement **o** is that all nouns belonging to this noun class are personal nouns.

The morphological structure of the concord does not show any similarity with the names in this class except with number, that is singularity. Noun class **2a** represents all personal names in plural form. The noun class prefix for this class is **Bo-**. To ensure plurality in noun class **2a** the Northern Sotho speakers, prefix the **Bo-** to a personal name. The concordial agreement for all names in noun class **2a** is **ba**. The consonant of the noun class prefix, resembles the consonant of the concordial agreement. There is therefore a closer similarity between the noun prefix and the concordial agreement in terms of form. The concordial agreement **ba** is used to indicate plural form for personal names.

NOUN CLASS	NOUN PREFIX	EXAMPLES	AGREEMENTS
1a	-	Aphane	o
	-	Kgwara	o
	-	Molatelo	o
2a	Bo-	Bo Aphane	ba
	Bo-	Bo Kgwara	ba
	Bo-	Bo Molatelo	ba

Examples for noun class **1a** looks as follows.

52.       Aphane o ngwala puku.  
            (Aphane is writing a book.)
53.       Kgwara o belege ngwana.  
            (Kgwara gave birth to a child.)

Examples of sentences showing concordial agreement in class **2a** are as follows.

54. **Bo** Aphane **ba** rekile dikoloi.  
(Aphane and company bought cars.)
55. **Bo** Mashudu **ba** feditše poledišano.  
(Mashudu and friends have finished talks.)

#### 2.4.1. Weak concordial agreement

Fowler (1980:1272) defines weak as something having less than the full or proper amount of a specific ingredient.

Opposite to the strong concordial agreements, are the weak concordial agreements prefixes. Their concordial agreements do not have the same morphemes as their noun prefixes as is the case with strong concordial agreement. Although the agreements in the construction brings undisputed grammatical relationship between noun phrases and other parts of the sentences they do not have the same structure.

NOUN CLASS	NOUN CLASS PREFIXES	CONCORDIAL AGREEMENT
1.	Mo-	o
3.	Mo-	o
4.	Me-	e
6.	Ma-	a
9.	N-	e
16.	Fa-	go
18.	Mo-	o



With regard to the weak concordial agreements the vowels of the noun class prefixes represented on the table above become the concordial agreement in those noun classes. The concordial agreement in classes 9 and 16 in the table above, do not have similarities with their noun class prefixes in terms of morphological structure. The following examples for noun classes 1, 2, 4 and 6 also do not have similarities with their noun prefixes, but their concordial agreements are similar to the vowels of the noun prefixes of the classes to which they belong.

### **NOUN CLASS 1**

56. Mosadi o kga meetse.  
(The woman is drawing water.)

### **NOUN CLASS 2**

57. Mohlare o metše thoko ga tsela.  
(A tree grew along the road.)

### **NOUN CLASS 4**

58. Menang e hlola malwetši.  
(Mosquitoes cause illness.)
59. Melete e epilwe kua mašemong.  
(Holes are dug at the fields there.)

## **NOUN CLASS 6**

60. Matšatši a go ngwala dithlahlobo a fihlile.  
(Days for writing examinations have arrived.)
61. Maope a epilwe ke dipula.  
(Dongas are dug by rains.)

## **NOUN CLASS**

62. Nko e tšwa mekola.  
(The nose is bleeding.)
63. Nku e lomilwe ke dimpša.  
(A sheep was bitten by dogs.)

## **NOUN CLASS 16**

64. Fase go omile.  
(The ground is dry.)

## **NOUN CLASS 18**

65. Morago go dula ba mahlo a mahubedu.  
(At the back, sit those with red eyes.)

66. **Morago go tla latela banna.**  
(Later, men will follow.)

Noun classes 16 and 18 use the **go** as a concordial agreement for location as the two classes are for locative nouns. They are used to bring agreement between a locative noun and a verbal phrase in the sentence. Class noun 9, which is a noun for animals and other parts of the body of a human being, uses the **e** as a concordial agreement. It also brings grammatical agreement between the subject noun and the verbal phrase in the sentence.

## 2.5. SYNTACTIC CHARACTERISTICS OF AGREEMENT IN CONSTRUCTED SENTENCES

### 2.5.1. Agreement appearing with noun phrase

Agreements appear with noun phrases in sentences to link both the subject and the verbal phrase. The following examples will be used in selected noun classes.

67. **Monna o bolela le basadi.**  
(Man is speaking with women.)

68. **Basadi ba rwele mekotla.**  
(Women are carrying bags.)

69. **Dinku di eme tseleng.**  
(Sheep are waiting at the road).

### 2.5.2. Agreement appearing on subject position

Agreement may appear at the beginning of the sentences as a pronoun, while the noun phrase is at the end of that sentence. Such a construction is done to show emphasis on noun phrase. The following are examples from selected noun classes.

70.       **O** boletše ka maitshwaro a badiredi ba mmušo , **mopresidente**.  
(He spoke about the behaviour of civil servants, the president.)
71.       **Ba** thophile sefoka, **bašemane**.  
(They won the prize, the boys.)
72.       **Se** tletše lehono, **sediba**.  
(It is full today, the fountain.)

### 2.5.3. Agreement appearing in the middle of the sentence

Agreement may appear in the middle of the sentence where it follows the verbal phrase. This is done for the sake of emphasis on the object in the sentences, hence their names, objectival agreement. Examples:

73.       Dikoloi mahodu **a di** utswitše.  
(Cars thieves have stolen.)
74.       Ditaba багаši **ba di** badile.  
(News broadcasters have read.)

#### 2.5.4. Agreement appearing in the place of noun phrase

Agreement may appear in the sentence where the noun phrase is left out as a pronoun. This means that the agreement may be used in the place of a noun phrase and still show the noun class to which the noun phrase of the sentence belong. Below are examples of such constructions:

75.       **Ba** bjetše merogo.  
            (They grew vegetables.)
76.       **O** feditše dithuto tša gagwe.  
            (She completed her studies.)
77.       **Se** kitima ka lebelo le legolo.  
            (It is travelling at a high speed.)

#### 2.5.5. Agreement appearing with absolute pronoun

Agreement may appear with absolute pronouns where the pronoun is repeatedly used to occupy both the subject and object positions for the purpose of emphasising the subject of the sentence. This is done with strong concordial agreements. Examples:

78.       **Bona ba** raloka kgwele ya maoto, **bona** .  
            (They are playing soccer ball those.)
79.       **Sona se** eme thoko ga tsela, **sona**.  
            (It is stopping along the road that one.)

80. **Lena le swere tšhelete lena.**  
(You are carrying money you.)

In the above examples, the pronouns are repeatedly used in both the subject and the object positions in order to emphasise the certainty which the speaker has about the subject in each sentence. In other words, the speaker is sure about what he or she is saying concerning the action of the subject in sentences 78, 79 and 80.

#### 2.5.6. Agreement appearing with pronoun and noun phrase

Agreement may appear with both the noun phrase and the absolute pronoun in a sentence in order to put emphasis on the subject of the sentence. Below are examples:

81. **Bana bona ba raloka ka mollo.**  
(Children them they are playing with fire.)
82. **Lehodu lona le swerwe maabane.**  
(The thief he was arrested yesterday.)
83. **Diaparo tšona di hlatswiwa lehono.**  
(Clothes them they are washed today.)

In Northern Sotho, there are a variety of ways in which emphasis can be done. In the examples above emphasis is achieved by using both the noun (name) and the pronoun, one following the other in a sentence on the basic subject position.

In this case, there is a pattern of one consonant repeating itself on the noun, pronoun, and the concord. This brings a notable agreement of words in a sentence as can be seen in examples 81, 82 and 83 above.

#### 2.5.7. Agreement appearing with compound noun

In any sentence, where the noun phrase is compounded and embracing human beings, the agreement will take the plural form **ba-**. The following will serve as ex

84.        **Bontši ke ba go dula ditoropong.**  
              (Many are those staying in towns.)

85.        **Bohle ke ba go tšwa Polokwane.**  
              (All are those from Polokwane.)

Compounded noun phrases represent plurality in actual fact, and shall always take the plural agreement. **Bontši** and **bohle** as they appear in sentences 84 and 85, represent nouns in their plural form and they thus take plural agreement **ba** for noun class 2 which represents human beings.

#### 2.5.8. Agreement appearing with a list of different races

When a noun phrase in a sentence consists of different lists of races the agreement will always remain a plural form, **ba-**, which shows honorific. Examples:

86. Ma-India, Makgowa, Matebele le Ma-Venda ke **ba** Afrika-Borwa.  
(Indians, Whites, Ma- Ndebele and Vendas are all citizens of South Africa.)
87. Ma-Sione, MaLutere, MaWesele le MaPosetola **ba** rapela Modimo.  
(Zionist, Lutherans, Wessels, and Apostles pray God.)

All names that appear in the lists in 86 and 87 above represent human beings. For this reason, the agreement **ba** is used as a way of showing respect. Human beings deserve respect and it is in this case that the appropriate agreement is used in addressing people of different races, ethnicity, background, and religion. This type of the agreement shows that one is speaking about human beings or is speaking to human beings who, obviously need to be respected.

## 2.6. CONCLUSION.

It is of major importance to notice that agreement in Northern Sotho construction cannot be divorced from noun classes. Noun classes are the springboard of any sentence formation.

On the other hand, it is to be noted that concordial agreement can be subcategorised into strong and weak concordial agreements. Strong agreements resemble their noun prefixes and have full identical features of morphology, while weak agreements have but little identity with their prefixes.



One interesting aspect in this chapter to be marked is the potentiality of agreements to move about with a sentence to ensure a different semantic value in the sentence. The concord can, at times, be moved to the subject position, to object position or work with or without pronoun and / or noun phrase. In so doing it moves with meaning of that sentence.

## **CHAPTER 3**

### **NOTIONAL AGREEMENT IN NORTHERN SOTHO CONSTRUCTION**

#### **3.1. INTRODUCTION**

The purpose of this chapter is to examine the role of notional agreement in Northern Sotho, and its effect on noun phrase and sentence meaning. The focus will be on to the use of agreement in different forms, such as plurality, singularity, honorific, respect, and diminution.

The use of an appropriate agreement, tells exactly whether one is aware of the importance of using such agreements, while on the other hand, using an inappropriate agreement may result in one breaking the healthy relationship between addressor and the addressee.

#### **3.2. DEFINITIONS AND STRUCTURE OF NOTIONAL AGREEMENTS**

According to Bartley (1996: 157) notional agreement refers to an agreement in which the relationship between the subject of a sentence and the verb is indicated by the meaning of the whole sentence itself and not by the form and tense of the verb. On the other hand, Webster (1989: 666) states that notional agreement is based on the meaning rather than the form of the sentence. Notional agreement contracts with formal or grammatical agreements, with overt marker-forms determining singular or plural agreement. On the other hand, Vivian Ridler (1972: 1946) defines it as follows: Notional is objective sign or viable token which serves to identify or distinguish something to denote circumstances or fact in connection therewith.

According to the definitions laid by Bartly Com, (1996:157), Webster (1989:666) and Vivian Ridler (1972:1946), there is no difference whatsoever. The main idea they emphasize is that notional agreement explains meaning which is carried by the sentence rather than the form or the subject of the sentence, it could be singular or plural. It is noted that some of the Northern Sotho sentences have a plural form but denote a singular meaning. Example:

88. Everyone is asked to be silent.  
(Yo mongwe le yo mongwe o laetšwe go homola.)

Some sentence structures on the other hand, have a singular form but denote a plural meaning. This is an example:

89. Hundred thousand Rand is spent on combating crime.  
(Diketekete tša diranta di šomišitšwe go thibela tshenyo.)

The English version of the above example (89) contains the concordial agreement indicating singularity of the subject, but the Northern Sotho translation contains the concordial agreement indicating plurality of the subject.

Notional agreement poses a problem every time when English sentences are translated into Northern Sotho because most translations do not give the exact meaning of English translations. English sentences may take plural noun phrases with singular verbal phrase, while the Northern Sotho sentences take plural noun phrases and plural verbal phrases or concordial agreements. Examples:

90. The news is read by Mr Brown.  
(Ditaba di balwa ke Morena Brown.)

91.           The Protea furnishers serves our community.  
(Lebenkele la difenišara la protea le thuša badudi bagešo.)

Just like example 89, the English construction in 90 and 91 above, does not coincide with the Northern Sotho translations.

When translating English sentences into Northern Sotho, whose English agreement is in plural form, and the meaning of the sentence reveals that the subject is singular, the sentence structure changes, but the meaning of the sentence does not change as is in examples 88,89,90 and 91.

### **3.3. CATEGORIES INTO WHICH NOTIONAL AGREEMENTS ARE FOUND**

#### **Introduction**

This subsection deals with categories into which Notional agreements are found. Among other categories which are discussed under this subsection, are noun phrases that are introduced in plural while their agreements have a singular meaning. Also discussed here are noun phrases that fall under class noun 9 representing singular form while they use agreements with plural meaning and noun phrases that represent liquid mass, that have singular form but have singular meaning. Noun phrases which seem to be huge and immense in structure, but use singular agreements. Abstract nouns always take a singular agreement. Names of organisations, institutions, clubs, co-operation use singular agreements, honorific take plural concordial agreements, questions directed to respected people use the *le* agreement. Honorific agreement to address strangers. The use of agreement which refer to object and animals, agreements referring to human beings with unbecoming manners and agreement referring to people with expertise in some fields.

**3.3.1. The agreement noun phrases that are introduced in plural forms gives a singular meaning**

There is in Northern Sotho an instance where certain noun phrases look like they indicate plurality, but have singular meaning. The following are a few examples of such cases in Northern Sotho:

92. Yo mongwe le yo mongwe o bolela segagabo.  
(Each and everyone speaks his language.)
93. Moloko wa gabo o kopane diofising.  
(His relatives are meeting at the offices.)
94. Phuthego e emetše moruti.  
(Congregation is waiting for the minister.)
95. Mohlape o fula nokeng.  
(Head of cattle is grazing at the river.)
96. Motšhitšhi wa dinose o lomile bašemane.  
(Swarm of bees has bitten the boys.)
97. Hlaba ya mabele e olelwa gosasa.  
(A heap of corn is collected tomorrow.)
98. Moela wa difatanaga o sepela ka go nanya.  
(The traffic is moving very slowly.)

99. Mang le mang o rapela Modimo wa gagwe.  
(Everyone is praying his God.)
100. Sengwe le sengwe se emetše mong.  
(Each one of them is waiting for the owner.)

The above sentences, have noun phrases that seem like they indicate plurality but have, in fact, a singular meaning.

Noun phrases in sentences 92 to 94 for example, represent a group of people each which seem to be in plural form. But, **Yo mongwe le yo mongwe**, refers to an uncountable number of persons, which in its meaning refers to a plural form. But when a study is conducted on it, it is realised that the agreement thereof denotes a singular noun phrase and form. Although it refers to a group of people within a context, the concord **ba-** was supposed to be used for plurality. The concord **o** is used to bring singular meaning.

In sentences 93 and 94 for instance, **Moloko** (relatives) refers to a range of people to whom a person relates. This noun phrase may be regarded as using plural agreement. In sentence 94, the noun phrase **phuthego** (congregation) refers to a big number of people of different backgrounds, culture, and ethics, socio- economic difference, and ages. This might be thought to be a plural noun but it remains with a singular agreement as it is collectively referred. In this case, the collective noun as referred to in sentence 94 above refers to a group of people belonging to a denomination, but the agreement used is the **e** for singular and not **ba** for plurality.

In sentences 95, 96, 97 and 98 the noun phrases used, seem to be referring to a plural number as **mohlape** (Head of cattle). This noun, **mohlape**, in 95 refers to a combination of cows, calves, bulls, with different creation that might be regarded as plural remains carrying a singular agreement. In sentence 96 **motšhitšhi** (Swarm of bees) and **hlaba** (heap of corn) which all refer to an uncountable number of insects and grains respectively, seem to be using a plural form, but are described with a singular agreement. It uses the agreement **o** for singularity and not **e** to denote a plural meaning. In sentence 98, the noun **moela** (traffic), which is a situation in which a number of cars move slowly one following the other, one may regard it as a plural noun phrase, but one finds it to be taking a singular agreement.

In sentence 99 and 100, the noun phrases **mang le mang** (Each and everyone) and **sengwe le sengwe** (each one of them) are in their actual meaning, referring to big numbers of people and objects or animals respectively, but in actual fact, they give a singular meaning in each case because the agreements **o** for **mang le mang** in sentence 99 and **se** in **sengwe le sengwe** in sentence 100 denote singularity.

It seems as though these noun phrases referred to are plural, but when an in-depth analysis is conducted, it is found that the agreement used for the two noun phrases is singular and refers to a singular subject as well.

### 3.3.2. Noun phrases that belong to class noun 9 represent singular form but use agreement with plural meaning

In Northern Sotho constructions, there are nouns which are used in singular form but have a plural meaning because of the plural agreement used.

Such agreement is plural in nature while the noun phrases are in singular form. Although it is possible to have the prefix **Di-** before nouns for class 10, it has become a daily language to omit the prefix **Di-** even when one is referring to plural nouns. The plural meaning in such constructions is obtained by using a plural agreement. The following constructions will serve as few examples in this case:

101. Tšhelete **di** bolokwa pankeng.  
(Money is saved in the bank.)
102. Kgomo **di** bolawa ke tlala.  
(Cattle is dying of hunger.)
103. Tšhemo **di** lengwa kgwedi ye.  
(Fields are ploughed this month.)
104. Kgwedi **di** latelana gabotse.  
(Months are following each other correctly.)
105. Tamati **di** rekišwa ka tšhelete.  
(Tomatoes are being sold for money.)
106. Kgogo **di** bea mae.  
(Hen lay eggs.)
107. Noga **di** kopile bana.  
(Snakes have bitten the children.)
108. Kereke **di** tsena ka 11h00.  
(Churches begin at 11h00.)



109. Puku **di** thapišitšwe ke pula.  
(Books are moistened of rain.)
110. Koloji **di** thulane.  
(Cars have collided.)

Nouns such as those in sentences 101,102,103,104,105 and 110, (**tšhelete, kgomo, tšhemo, tamati, kgogo, noga, kereke, puku and koloi**) fall under noun class 9. This noun class deals basically with nouns in their singular form, but agreement of such nouns is plural.

There is a tendency among Northern Sotho speakers to leave out the prefixes **Di-** on some nouns, especially under class 9. This tendency of leaving the prefix **Di-** on names which deserve it, leave those names with a singular structure. When such names are used in the sentences, and a plural agreement is employed, the use of such agreement can change the meaning of the sentence from singular to a plural form.

The use of a plural agreement **di** for noun class 10 has the capacity of changing the meaning of most sentences from a singular form to a plural form. In other words, it does not matter if the noun was written in singular form, but as long as the agreement is in plural form. In this case the whole sentence will take the meaning of the agreement. What it means is that, the agreement in a sentence has a profound influence on sentence meaning than the noun phrase used in that sentence.

**3.3.3. Noun phrases that represent liquid mass, do not have singular form but have singular agreement / meaning**

In Northern Sotho all liquids are never in singular form but when a construction is done the agreement gives them a plural meaning.

When the nouns that are referring to liquid mass appear within a construction, the agreement often yields the plural meaning. The following are a few examples.

111.       Meetse a tletše nokeng.  
              (Water is full in the river.)
112.       Madi a tloiditše diaparo.  
              (Blood has smeared on clothes.)
113.       Maswi a tletše kgameo.  
              (Milk is full in the bucket.)
114.       Bjalwa bo nwewa ditoropong.  
              (Liquor is drunk in town.)
115.       Oli e rekišwa ditoropong.  
              (Oil is sold in town.)
116.       Pula e nele bošego.  
              (It rained late night.)
117.       Khokhakhola e tletše lebotlelo.  
              (The bottle is full of coca-cola.)

All noun phrases that appear in sentences 111-117 above, represent liquid masses. Liquid masses such as **meetse** (water), **madi** (blood), **maswi** (milk), **bjalwa** (liquor), **pula** (rain) and **khokhakhola** (coca-cola) represent a volume of big mass of liquid which can be regarded as having a singular meaning, but when they appear within a construction, the agreement often yields a plural meaning.

The agreement for most nouns such as **meetse** (water), **madi** (blood) and **maswi** (milk), can yield a plural meaning, because these nouns do not have singularity or plurality. The agreements **bo** for **bjalwa** (liquor) and **e** for **oli** (oil), **pula** (rain) and **khokhakhola** (coca-cola) in most cases indicate a plural form irrespective of the fact that these nouns may sometimes take a **Di** – prefix to denote a plural form with **di** as its agreement denoting plurality in some cases. Examples for the above explanation are:

118.        **Dioli di tloiditše diaparo.**  
              (Oils have smeared on clothes.)
119.        **Dipula di na selemo bošego.**  
              (Rains fall during summer nights.)

The two examples above, have noun phrases using the prefix **Di-** and the agreement **di** both for noun class 10. The main purpose of using prefix **Di-** and the agreement **di** is to emphasise the various types of oils, rains and the extent to which oil smeared the clothes while in the second sentence it emphasises the extent of rain falling during summer.

### 3.3.4. Huge and immense noun phrases using singular agreements

Certain noun phrases, which seem to be immense and massive in structure and form that may be regarded to be plural in nature, are found to be singular in sentence meaning. The following are some of the examples:

120. Moriri o mela hlogong.  
(Hair grows on the head.)
121. Moriti o botse selemo.  
(Shade is good during summer.)
122. Mobu o thapišitšwe ke pula maabane.  
(The ground was moistened by rain yesterday.)
123. Motse o dikaneditšwe ke manaba.  
(The village is surrounded by the enemies.)
124. Mmušo o beile molao wa naga.  
(The government proclaimed the Land Act.)
125. Kgoro e mmeile molato.  
(The court found him guilty.)
126. Muši o tletše ka ngwakong.  
(The house is full of smoke.)

In the above examples, noun phrases that explain huge and immense structures, which are regarded as plural, are found to be using singular agreements.

In sentences 120 to 124 for instance, the noun phrases **moriri** (hair), **moriti** (shade), **mobu** (ground), **motse** (the village) and **mmušo** (government) can be taken to be structures that are composed of a large component made up of different bodies or fragments that could be counted as many elements that form a whole structure.

These structures are huge and immense and according to one's understanding, they could be using a plural agreement. When an in-depth study is conducted on notional agreement, it is discovered that the meaning embodied in such sentences, is singular.

Sentences 125 and 126 have noun phrases **kgoro** (court) which represent a group of men who are engaged in resolving cases in court. These men and women are many in number and it can be understood that when this noun phrase is used in a sentence it would take a plural agreement, but this is not the case.

The noun **muši** (smoke) as it appears in sentence 126, represents a singular meaning although in essence **muši** (smoke) comprises of many tiny particles of dust and smoke particles that could be regarded as plural, but instead it takes a singular agreement.

### 3.3.5. Abstract nouns always take singular agreements/ meaning

Nouns that are abstract in nature will always have a singular form because they represent phenomena that cannot be counted as they cannot be seen or touched. We will consider a few examples below:

127. Bohodu **bo** a bolaya.  
( Theft kills.)

128.        **Bootswa bo thuba malapa.**  
               (Fornication breaks families.)
129.        **Bobodu bo hlola bohodu.**  
               (Laziness causes theft.)
130.        **Bodumedi ga bo ratege.**  
               (Believing is never preferred.)
131.        **Boetapele bo bose.**  
               (leadership is enjoyable.)

All nouns that fall under this category, belong to noun class 14. These nouns may not show singular form or a plural form, but when they are used in a construction, they take a singular agreement.

In sentences 127, 128, 129, 130 and 131, for example, the agreement **bo** as it is used, represent a singular meaning. Abstract nouns do not indicate plurality or singularity. The agreement for all those nouns take the form of a noun prefix of that class noun.

### **3.3.6. Names of organisations, institution, clubs, co-operations use singular agreements**

Large organisations, institutions, clubs, co-operations and industries which employ large number of workers are always addressed using a singular agreement. Their sizes in terms of organisational matters and the great jobs they perform do not give them credit to be addressed with plural agreement. Below are a few examples:

132. United Nations e hlolwa ke go rarolla mathata.  
(The United Nations is unable to resolve problems.)
133. Yinibesithi ya Lebowa e aba digrata tša molao.  
(The University of the North is awarding the degree of law.)
134. SADTU e dira kgwabo ka seboka.  
(SADTU is launching a mass action.)
135. ISCOR e butšwe la mathomo ka Pretoria.  
(The first ISCOR was opened in Pretoria.)
136. Pirates e ralokile le Amazulu.  
(Pirates played Amazulu.)
137. Kgoro e ahlola molato.  
(The tribal court is at hearing.)

Although the names of organisations, institution, clubs, and co-operations are perceived to be big and consisting of a great number of workers and managing directors, they are addressed to as one single organisation which takes a singular agreement.

The noun phrases United Nations, in sentence 132 for example, is a world organisation consisting of various organs such as the general assembly, secretariat, security council, and many others that may be referred to as plural, but remain with a singular agreement.

In sentences 133,134, and 135, the nouns **University**, **SADTU**, and **ISCOR**, have different structures within one big body/ organisation. Instead of being viewed as a noun to take a plural form, they take a singular agreement.

In sentences 136 and 137 **Pirates** and **kgoro** (court) both consists of a number of persons that compose a structure. These structures, **pirates** and **kgoro** (court) in each of the nouns in 136 and 137, do not give these nouns credit to be addressed as plural.

### 3.3.7. **Honorific take plural concordial agreement**

It is common practice among Northern Sotho speakers to prefix the **Bo-** before names and titles of elderly persons, respected officials of government, people from royal families, traditional doctors and other important people in the society, as a way of respect. All these names fall under noun class **2a** which represents personal names and titles of individuals in their plural forms. When their names and titles are prefixed with **Bo-**, the agreement used in the construction remains **ba**, as though it is carrying a plural meaning while it is not the case, but remains with honorific meaning. Examples:

138. **Bokoko ba** re reketše kgogo.  
(My grandmother bought us a chicken.)
139. **Bohlogo ya sekolo ba** re rutile dipalo.  
(The principal taught us Arithmetic.)
140. **Bongaka ba** re alafile malwetši.  
(The doctor cured us from diseases.)
141. **Bokgoši ba** rarolotše mathata a ka.  
(The chief solved my problems.)
142. **Bomoporesidente ba** boletše le setšhaba.  
(The president addressed the nation.)



143. **Bomoruti ba** re rutile lentšu la Modimo.  
(The pastor preached us the word of God.)

144. **Bomma ba** nthomile toropong.  
(My mother sent me to town.)

All the above examples, use the **bo-** prefix to all names and titles of some people as a way of respect. When the **bo-** is prefixed to all the names, the agreement in the construction remains **ba** as though the addressee is in the plural form. When one analyses sentences 138, 139, 140, 141, 142, 143 and 144, one realises that the meaning embodied plurality as it is the case in the above examples.

### 3.3.8. Questions directed to respected people use the le agreement

When questions are directed to elderly persons, strangers and respected people, in Northern Sotho, respect is shown by using the **le** agreement in the plural construction. The agreement **le** originates from class noun 5 for **Le-** prefix. The agreement in this case does not grammatically refer to the **Le-** as in class 5, but is used to show respect. The structure of the sentences will seem as though it is a plural agreement, while it is not the case but shows a honorific meaning. Below are some examples:

145. Tate, **le** tlile neng?  
(When did you arrive father?)

146. Kgoši, **le** re re tle neng?  
(His honour, when must we come?)

147. Morutiši, **le** biša rena?  
(Sir, are you calling us?)

148. Re ka le thuša, tate?  
(Can we help you dad?)

In the above examples, it is realised that the agreement **le** is being used to help formulate questions showing respect when addressing elderly persons and strangers.

In essence, the **le** agreement is known to be used to refer to nouns in which the meaning will become plural. In the case of the above constructions, it is used to show respect rather than showing plurality.

The noun phrases in sentences 145, 146 and 147 i.e. **tate**, **kgoši** and **morutiši**, are respected persons in our society, as such they may not be addressed like ordinary persons, they deserve respect, and so an agreement **le** is necessary every time when they are addressed.

### 3.3.9. Honorific agreement to address strangers

Northern Sotho speakers have a respectful way of addressing people who they see the first time by using the agreement **le** and **ba**. When they speak to people they are not familiar with, they show respect to such strangers by talking to an individual person as if they are talking to more than one person by using the **le** and **ba** agreements normally used for plurality. The following are some of the examples:

149. Malome, le tšwa kae gae?  
(Uncle, where do you come from?)

150. Mma, le nyaka dinamelwa tša go ya kae?  
(Mam, which transport are you looking for ?)
151. Mohumagadi ba ba šoma kgašong.  
(This lady is working at the SABC.)
152. Monna ba, ba nyeše sesi.  
(This man is married to my sister.)
153. Morena, le boile maabane?  
(My worship, have you arrived yesterday?)
154. Kgaetšedi ba lebogile kudu.  
(My sister thanked it so much.)
155. Kgare ba mpiditše  
(Mr Kgare called me.)

The agreement used in the above constructions have a special meaning to the people/persons addressed. When addressing strangers, it is important to give them respect. This is done to keep a healthy relationship and to avoid quarrels with unknown people, as some of them might be community leaders, government officials or people who occupy high positions in their societies.

The agreement **le** and **ba** as used in the constructions above, do not indicate any forms of plurality to the noun phrase, but show a honorific meaning. In noun phrases all the constructions appear in singular form, but their agreements take the plural form while the meaning deviates to the honorific.

In sentences 149, 150, 151, 152, 153, 154 and 155, all the nouns are singular; (examples are **malome** in 149, **mma** in 150 and **mohumagadi** in 151), but have agreement, which seems to indicate plurality and ends up with honorific meaning.

### 3.3.10. The use of agreement which refer to objects and animals

Objects and animals are not addressed the same way human beings are. There are different types of agreement used to address animals and objects. There are also specific types of agreement used to address human beings. As agreement used to address animals do not show any respect, such type of agreement may not be used to address human beings. If it happens that by mistake an agreement of such nature is used to refer to a human being it may offend the person in question. In simple terms, it is important to guard against such mistakes when speaking to familiar and unfamiliar people. Below are examples of agreements used to refer to objects and animals which are not allowed to refer to human beings dead or alive.

156.        Namane e anywa kgomo.  
              (The calf is sucking the cow.)
157.        Noga e lomile ngwana.  
              (The snake has bitten the child.)
158.        Tlou e feta diphoofolo ka moka.  
              (The elephant is bigger than all the animals.)
159.        Noka e tletše meetse.  
              (The river is full of water.)

160. Thaba e pipilwe ke maru.  
(The mountain is covered with clouds.)
161. Dinku di fula nokeng.  
(Sheep are grazing at the river.)
162. Dikepe di tshetsha lewatleng.  
(The ships are sailing in the sea.)

Noun phrases in the above examples, belong to class 9 and 10. These noun classes are associated with animals, objects, and natural phenomena. They do not include human beings and cannot use agreements that refer to human beings. The agreement e as used in constructions 156 – 160 indicates that the noun phrases referred to, belong to class 9. This agreement can also indicate that the noun phrase is in singular form because of the meaning it provides to the sentences.

Agreement di in sentences 161 – 162, deals with nouns for class 10. The agreement itself indicates that the sentence is already in plural form because of the agreement, which is plural.

### 3.3.11. Agreement referring to human beings with unbecoming manners

Individuals with unbecoming manners and behaviour are taken as objects or animals. When the society talk about them, they address them like animals and objects by using agreements which are suitable to animals. Below are some examples which are used to refer to animals, but this time are used to address those nonsense people.

163. Tsotsi e swerwe.  
(A thug is convicted.)
164. Kgeke e thuntšhitšwe.  
(A prostitute is shot.)
165. Mpheane e sekišitšwe.  
(A liar is interrogated.)
166. Sekata se swerwe.  
(The rapist is arrested.)
167. Lehodu le bolailwe.  
(A thief is murdered.)
168. Diotswa di rekiša mebele.  
(Prostitutes are doing business out of their lives.)

The agreements used in the above examples refer to most animals that fall in classes 9, 7, 5, and 8. It has become the norm among Northern Sotho speakers to use the above agreements to address the misfits in the society because of their behaviour. In short, those people have lost their dignity and do not enjoy the respect of their own people in the community and society they live.

The agreement **se** as it is used in sentence 166 for example gives a wrong meaning if it is used to refer to a human being whose way of life is accepted by his people.

### 3.3.12. Agreements referring to people with expertise in some fields

Contrary to the explanation in sub-section 3.3.11, there are, in the society, those people who are honoured for their expertise in different fields of sports, music, art, politics, education, etc. such people enjoy the maximum support and honour of their own society in which they live. In addressing such people, the society uses the agreement which is normally used to address animals and objects, but this time the meaning maintained in such sentences will indicate bravery, expertise and honour. Let us consider the following examples:

169.        Doctor Khumalo ke seraloki **se** maatla.  
              (Doctor Khumalo is a strong player.)
170.        Brenda Fassie ke seopedi **se se** tumilego.  
              (Brenda Fassie is a famous musician.)
171.        Ramolomo ke seboledi **se** tsebegago.  
              (Ramolomo is a famous speaker.)

Although there are but a few examples in some noun classes, which can indicate the use of agreement **e**, **le**, **di**, and **se** there are a few which can indicate honour to some people because of the expertise they have in one way or another. The agreement **se** as it is used in the above examples, can be used to indicate both the bad and good persons.

### 3.3. CONCLUSION.

Notional agreement in Northern Sotho construction can be used to denote plurality, singularity, honorific, diminutive, derogative, in sentence meaning than it is to sentence structure and form. Notional agreement differentiates between singular and plural nouns. Certain nouns may have plural structure but their agreement may have a singular meaning depending on the sentence. On the other hand, some nouns may appear in singular, while denoting a plural meaning. This is because of a plural concordial agreement as in 3.3.8 above. It is important to mention that a certain agreement is employed in a sentence in order to show respect to the noun referred to in the sentence as in question 3.3.8.

Some of the agreements used to refer to animals and objects can also be used to refer to people whose behaviour is bad, as well as people with a sense of honour in their societies. Agreement can also be used to identify the importance of meaning when translating English sentences to Northern Sotho as meaning and structure differ between these two languages.

On the other hand, a noun in Northern Sotho that seem to be referring to something compound, massive, large or consisting of co-operates may remain using singular agreement, but retaining a plural meaning, as the following examples show:

172.        **Mobu o thapile**  
              (The soil is moist.)
173.        **Motse o godile.**  
              (The town is develop.)



## **CHAPTER 4**

### **THE MORPHOLOGICAL STRUCTURE OF THE AGREEMENT**

#### **4.1. INTRODUCTION**

The purpose of this chapter is to further examine the morphological structure of the agreement in various forms in which it occurs, such as how it is treated in syntax with regard to subjectival and objectival agreement; origin of agreement on nouns; grammatical agreement and how inflection affects agreement; notional agreement, and agreement by proximity and the distribution of agreement morphemes. The chapter will also examine whether noun classes 1a and 2a, first and second persons, subject and object concords, follow the same pattern as the agreement mentioned above. The chapter will include demonstratives as well.

#### **4.2. DEFINITION OF CONCEPTS**

##### **4.2.1. Morphology:**

Hornby (2000:762) defines morphology as the form of word or structure of words in a language. Vivian Riddler (1970:670) supports Hornby by defining morphology in a similar way as she says that morphology is a branch of grammar which is concerned with the form of words, including word formation and inflection. In his definition, Matthews (199:9) defines morphology as the branch of grammar that deals with the internal structure of words.

On the other hand, Spencer (1998:152) augments the above definitions by pointing out that morphology is “.... word formation component that must show that a component includes operations and constraints which cannot be reduced”.

#### 4.3. HOW AGREEMENT IS TREATED IN SYNTAX

It will be proper here to focus on inflection, since agreement forms part and parcel of inflection. According to Ntsundeni (2002:7), inflection morphemes refer to those grammatical categories that come before the verb stem such as mood, tense, negatives, agreement, and aspect. At the same breath, Vivian Riddler (1970:268) defines inflection more vividly as a lexicon added to the termination of words in order to express different grammatical relations (adjectives), to bring a new form in those words to effect (indicate) change in its meaning and use. Inflectional morphemes may be illustrated as follows on a tree diagram:

174. Mootledi a se sa emiša sefatanaga .  
 (The driver should no longer stop the car.)

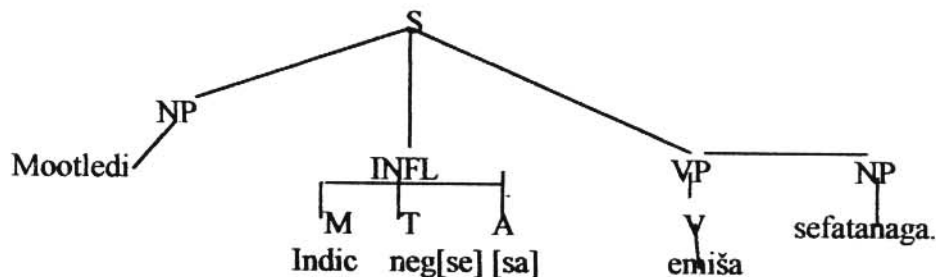

In the above sentence, the subject noun (NP) mootledi (driver) falls under class noun 1. The tense (TP) of the sentence is present, the mood (MP) is indicative, and the sentence is in the negative form. The negative morpheme is se.

The verb phrase (VP) of the sentence is emiša (stop). The objectival phrase (OP) of the sentence is sefatanaga (the car), and the agreement (Agr) is a.

#### 4.3.1. INFLECTION

As already indicated agreement can best be treated under inflection as it forms part and parcel of the inflection.

##### 4.3.1.1. *Agreement*

According to Godi (2002:52) Agreement means to agree or to be in accord or to match. This is true because people or things that agree with each other have the tendency to go together because they have something that binds them together. This is applicable in language as well. There is a relationship among words that channel these words to stick together in order to make a meaningful statement. Crystal (1997:14) is in agreement with Godi's statement when he says:

The term agreement is used to refer to a formal relationship between elements, whereby a form of one word requires a corresponding form of another.

Crystal (1997) confirms the fact that there is an existing relationship among words. He further highlights that the form in which words find themselves is governed by other words in the same sentence. In a sentence such as the following, for example, inflectional morphemes govern others:

175. Morutiši o ruta bana dipalo.  
(The teacher teaches children mathematics.)

The agreement morpheme **o** governs the noun **Morutiši** (the teacher). The noun **bana** (children) and **dipalo** (mathematics) in the object position are governed by **ruta** (teaches). In this case, the lexical head governs complements. Nouns can never govern but are always governed.

Besides the grammatical relationship of words in a sentence construction, agreement appears; in two distinct ways, such as the subjectival agreement and the objectival agreement. In his discussion of the agreement morphemes, Madadzhe (1992:148) points out that nouns generate concordial morphemes through their class prefixes by which other words agree with nouns.

#### 4.3.1.2. *Subjectival agreement*

In this section attention will be focused on the agreement of the subject and verb of the sentence.

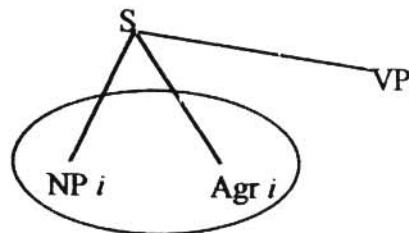

The section will basically outline how the subject concord functions with the verb in a sentence, such as in this example:

176. Monna o bolela sekgowa.  
(The man is speaking English.)

The same sentence can diagrammatically be represented as follows:

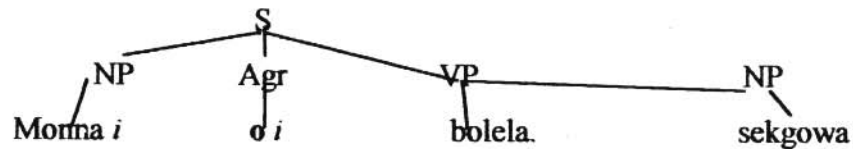

According to Godi (2002:56) subjectival agreement is the agreement morpheme that brings the concordial agreement between subject of the sentence and the verb of the sentence. Let us consider the following example:

177. Dikgomo di fula bjang.  
(Cattle are grazing.)
178. Bana ba raloka kgwele.  
(Children are playing soccer.)

The subjectival agreements **di** and **ba** as they appear with **dikgomo** (cattle) and **bana** (children), in noun class 10 and 2, generate agreement between the noun phrases **dikgomo** (cattle) and **bana** (children) and **fula** and **raloka** (play soccer) respectively. It is evident that the noun phrases **dikgomo** (cattle) and **kgwele** (soccer), would not agree with other words in the sentence if the agreement used was not **di** and **ba** respectively.

The above sentences show that the **di** and **ba** appear as the subjectival agreements for the noun phrases **dikgomo** (cattle) and **bana** (children). These agreements bring grammatical relationships between **di** and **dikgomo**, and **bana** and **ba**.

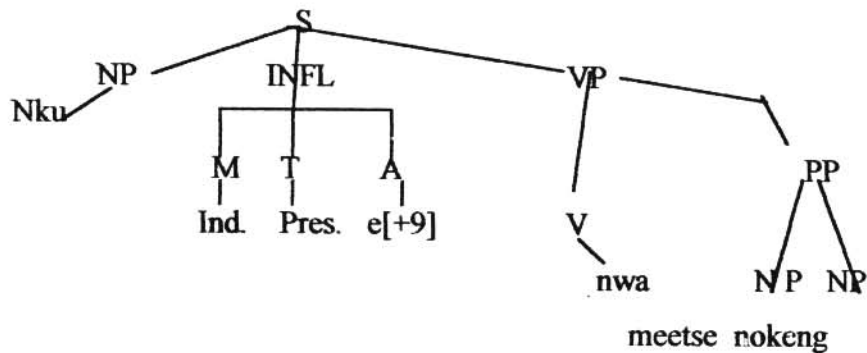

It is clear that the inflectional morphemes in particular agreement can govern all the words to the left of the verb in the sentence. Let us consider the following examples:

179. Nku e nwa meetse nokeng.  
(The sheep drinks water in the river.)
180. Monna o bolela lekgotleng.  
(The man is speaking at the meeting.)

In the two sentences above, the inflections **e** and **o**, govern the noun phrases **monna** (the man) and **nku** (the sheep) respectively, and assign a nominative case. It is clear that the agreement **o** and **e** cannot agree with any noun phrases other than nouns in 1 and class 9 as they appear in the examples above. On the other hand, the subject depends upon its inflection for it to be governed. Government as Haegeman (1999:365) puts it, is from left to right.

The inflection governs the NP, while the VP governs the NP (object) to the most right of the sentence, and assigns an objective case. If the VP governs the locative, it assigns a locative case to the locative noun in question. The above explanation can be illustrated as follows on a tree diagram:

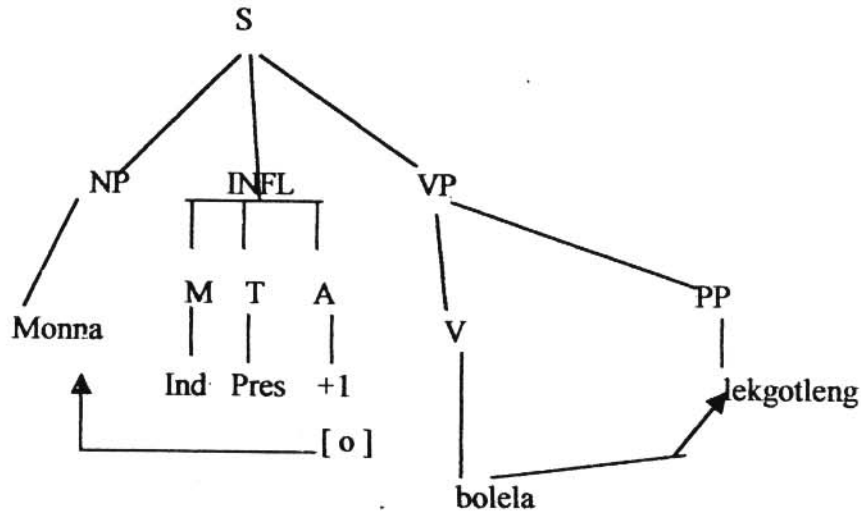

181. Monna o bolela polelo  
(The ma is speaking the language.)

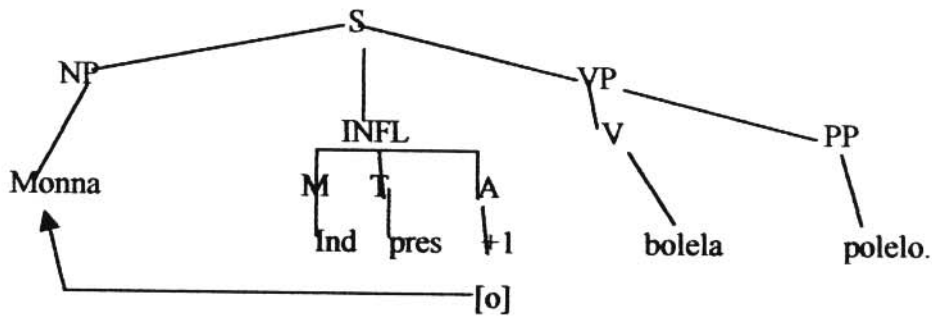

In the above sentences, the agreement **o** governs the NP (subject) monna (the man) and assigns a nominative case.

This means that there is a grammatical agreement between the Noun Phrase and the verbal phrase which is brought by the agreement **o** in the sentence. In other words, **monna** cannot be in good relationship with **bolela** if the agreement used in the sentence was not **o**. The agreement **o** governs the noun phrase **monna**.

On the other hand, subjectival agreement as Louwrens (1991:14) puts it, refers to referents which are known to the speaker and the addressee. He indicates that subjectival agreement presents old or known information within a particular context, by deleting the NP (subject) which was mentioned earlier in the discussion. The following are examples:

182.       **O** ile sekolong.  
              (She is left for school.)

183.       **O** a lwala.  
              (She is sick.)

In the above examples, the NPs (subjects) have been deleted for the fact that they are known to both the addressor and the addressee because they were mentioned earlier in the discussion. When at this stage the NPs are deleted, the subjectival concord serves the pronominal function, since it is used to refer to the known referent to both addressor and the addressee.

At the same time, when the subject is mentioned explicitly, the subject concord functions as the agreement morpheme, which marks the grammatical relationship between the NPs and the VPs.



#### 4.3.1.3. *Grammatical agreement*

It was indicated at the beginning of this chapter that a verb must agree with its subject in person and in number. Louwrens (1991:13) is also of the same opinion. He supports this statement by saying that grammatical subjects always agree with the verb by means of a subject concord or grammatical concord. He further says that the basic syntactic position of the grammatical agreement is the position directly to the left of the verb.

One basic function of grammatical agreements, is that they bring grammatical agreement between the subject NPs and the verb or other words in the sentence. What it means is that singular subjects always take singular grammatical agreements, while plural subjects will take plural agreements. Below are a few examples:

##### **A. Singular agreement**

184. Ngwana **o** raloka mokgotheng.  
(The child is playing in the street.)

185. Mpša **e** bogola bošego  
(The dog barks at night.)

##### **B. Plural agreement**

186. Dinku **di** fula nokeng  
(Sheep are grazing at the river.)

It can be noted in the above examples that singular subjects take singular agreements, and that plural subjects take plural agreements. In his statement, Bartley (1996:3), supports Louwrens's (1991) idea by saying that in grammatical agreement a verb must agree with subject in person and number, and that singular subjects take singular verbs, and plural subjects take plural verbs.

In line with what Bartley (1996) and Louwrens (1991) say, Thwala (2003:1) briefly augments their statements by saying this about grammatical agreement:

One subject agreement (SA) morpheme per verb clause. The subject agreement morpheme is a prefix to the verb. Subject agreement prefix occur at the leftmost element on the verb.

From what Thwala (2003 ) alludes, it is clear that grammatical agreement is characterized by subjectival agreements agreeing with their subjects in terms of number and person. Below are a few examples:

187. Mosadi o apea bogobe.  
(The woman is cocking porridge.)

188. Basadi ba apea magobe.  
(Women are cocking porridge.)

In the examples above, the subjects of the sentences agree with their subjectival agreements in terms of number and person. In example 187 for instance, has the subject (mosadi) the woman is in the singular form and the agreement o also appears in the singular, and this relationship between subject and its agreement makes it possible for the sentence to carry a meaningful idea.

Example 188 above is no exception to the rule. In its case, the subject (basadi) the women is in the plural form and the agreement **ba** is also in the plural form. This corresponds both with the subject in the sentence and the subjectival agreement to convey a meaningful statement.

#### 4.3.1.4. Objectival agreement

Under this sub-section the agreement of the object with the verb of the sentence will be fully discussed. More attention will be given to the aspects of languages that bring grammatical agreement between the verb and the object in a sentence.

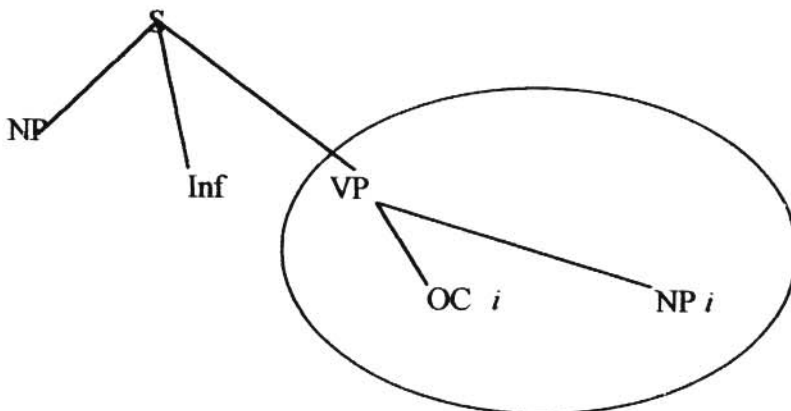

The objectival concord is the object morpheme which brings agreement between the object and the verb in the sentence. More often than not, this morpheme is used to represent the object noun when the noun is deleted in a sentence construction. On this view of the objectival agreement, Paulos et al.(1994:174) point out that objectival agreement is used in certain contexts or situations and that when they occur, they are placed immediately before the verb, and that at times they occur with the object noun or may occur without the noun but representing the object noun.

A verb as Vivian Ridler (1970:789) puts it, is that part of the speech by which an assertion is made, or which serves to connect the subject of the sentence with the predicate. Louwrens (1991:17) adds to Ridler's (1970) argument on verbs by saying that a verb in a sentence need not be complemented by another verb in the same sentence. This means that a verb is independent in a sentence and can convey the information without being helped by another word. The primary function of the verb is to explain the action of the subject (NP) in the sentence. Let us take one example:

189.       Mma o **apea** bogobe.  
              (Mother is cocking porridge.)

In the above example, the word **apea** (cocking), is a verb. It tells us what the NP (subject) is doing. The action of the mother **apea** (cocking) is independently explained in the sentence by the verb without being assisted by another word in that sentence. Lombard et al. (1984:103), indicate that the objectival agreement is derived from the class prefix of the noun, but in this case it is the noun which acts as the grammatical object in the sentence.

### **Noun Class 2a**

The objectival agreement for the noun class **2a** differs greatly from the objectival agreement of the noun class **1a**. The nouns from noun class **2a** which represent plural nouns take **Bo-**. As witnessed in earlier paragraphs their objectival agreement is **ba**. Let us consider the following examples:

	<b>Column A</b>	<b>Column B</b>
190.	Re bone <b>bomalome</b> . (We saw Malome and company.)	Re <b>ba</b> bone. (We saw them.)
191.	Ke rata <b>boresi</b> . (I like ladies.)	Ke a <b>ba</b> rata. (I like them.)

Examples 190 and 191 above, in column B, indicate that the objectival concord in both sentences is **ba**. The agreement **ba** refers to the deleted object NPs (**bomalome** and **boresi**) which appears in sentences 190 and 191 under column A respectively. Although the agreement **ba** in the two sentences have the same morphological structure, they do not have the same meaning.

In the above examples, the agreement **ba**, in column B sentence 190, expresses the meaning of respect. Although **malome** can be in singular form, it will still be addressed with agreement **ba** as a way of showing respect, while **ba** in column B sentence 191, means plural form which means that the speaker likes many ladies. At times it is not easy for a stranger to understand or to know the name of the person referred to in the discussion if he was not told the name before.

The agreement **ba**, as used in the two sentences above, represent particular nouns. The agreement **ba** does not have meaning when it is used in isolation because it does not specify the noun, but generalises many nouns. In their definition of the object concord, Paulos et al (1994:174), maintain that the object concord is that element of the verb that shows agreement with the object noun.

What Paulos et al. (1994) mean about objectival agreement is that object concords are those words in a sentence that bring agreement in a sentence between the verb and the object noun. This explanation can be illustrated as follows:

- 192.a. Monna o a **le** reka lerumo.  
(The man is buying (it) the assegai.)

In the above example, the objectival agreement is **le**. This agreement brings the relationship between the verb stem (**reka**) and the object noun (**lerumo**) of the sentence. In most cases the object concord may be left out in the sentence, such as in the following example:

- 192.b. Monna o a reka.  
(The man is buying.)

Both the objectival concord and the object noun phrase are left out in the construction. This makes it difficult for the man who does not know the object noun or referent before the discussion to understand what the speaker is actually buying.

At time agreement can be used without mentioning the object noun. Such a construction also poses some problems of understanding the referent. To a lesser degree, the stranger can understand that the speaker is talking about something which falls under the noun class of animals, non-living objects i.e. class nouns 7,8, 9, 10, and 14. If the speaker uses the agreement **m-** or **ba-**, then the stranger will assume that the referent is a human being or human beings. Such constructions are as in the examples below:

- 193.a.    **Monna o a le reka.**  
           (The man is buying it.)
- 193.b.    **Mosadi o a mmitša.**  
           (The woman is calling him.)
- 193.c.    **Mosadi o a ba bitša.**  
           (The woman is calling them.)

The agreement **le** in 193.a above indicates that the object noun, which is not mentioned, falls under noun class 5, and it represents an object and not a human being in this case. In example 193.b for instance, the agreement **mm-** stands for second person singular and the object noun is omitted and the agreement **mm-** takes the function of the object noun. In sentence 193.c the agreement **ba** is used to represent the second person plural.

The reason why the object concord is used without mentioning the object noun is that the addresser and the addressee have the same previous knowledge about the referent. In the above sentence, the object concord, like the object noun, belongs to noun class 5. It refers to non-living things.

The objectival agreement like the subjectival agreement, is in most instances identical in form to its corresponding objectival noun prefix. Exceptions are those of the 1<sup>st</sup> person singular and those nouns that fall under class 1. The objectival agreement for the 1<sup>st</sup> person singular is **ke**; for the 1<sup>st</sup> person plural is **re**; for the 2<sup>nd</sup> person singular is **o**, and for the 2<sup>nd</sup> person plural is **le**. The following are a few examples:

**1<sup>st</sup> person singular -N-**

194. Matome o tseba **nna** / Matome o a ntseba nna.  
(Matome knows I/ Matome knows me.)

In the case of first person plural, the prefix **re-** for noun **rena** and the agreement **re** for the first person plural are similar in characteristic feature and correspond in meaning.

The nasal consonant **n** in this case has been used to represent the objectival concord for the first person singular, which is formed by the prefix **n** for **nna** (I).

**1<sup>st</sup> person plural -re-**

- 195.a. Matome o tseba **rena**/ Matome o a re tseba rena.  
(Matome knows we/ Matome knows us.)

The objectival agreement for the first person plural is **-re-**. This object concord morphologically corresponds with the prefix **-re-** for the pronoun **rena** (us) in sentence 195.a above.

**2<sup>nd</sup> person singular**

- 195.b. Matome o tseba wena./ Matome o a go tseba wena.  
(Matome knows you/ Matome knows you.)



The objectival agreement for the 2<sup>nd</sup> person singular is **go**, but it does not fully correspond with the pronoun for the second person singular **wena**, in terms of the structure as it uses a semi-vowel **w**.

## 2<sup>nd</sup> person plural

196.        **Matome o tseba lena/ Matome o a le tseba lena.**  
              (Matome knows you./ Matome knows you.)

In the above examples, the objectival agreement **n-**, **m-**, for 1<sup>st</sup> person singular indicate that an object noun **nna**, has a grammatical relationship with objectival agreement **n-** for **ntseba** as it appears in example 194 above. The agreement **m-** or **n-** brings grammatical agreement between the verb and the object noun.

In example 195.a for instance, the objectival agreement **re-** for 1<sup>st</sup> person plural corresponds with the prefix of the object noun **rena** in form, in number, and meaning. The object noun **wena** for 2<sup>nd</sup> person singular, as in example 195.b corresponds with objectival agreement **go** which is written before the verb. Although the **go**, agreement for 2<sup>nd</sup> person singular brings agreement between the verb and the object noun, it does not correspond with the 2<sup>nd</sup> person pronoun in terms of structure; but corresponds with the pronoun **wena** in meaning only.

The object agreement has also proved to stand in the place of the noun when the noun is omitted, or to function with the object concord on the sentence for the purpose of giving it a different meaning in the sentence.

Noun classes have the following objectival agreement which correspond with their NPs:

Noun class	Noun prefix	Object agreement	Examples
1	Mo-	mm-	Ke bona Lolo./ Ke a <b>m</b> mona.
1(a)	-	mm-	Re betha Seetla./ Re a <b>m</b> metha.
2	Ba-	Ba-	Ke bona batho./ Ke a <b>ba</b> bona.
3	Mo-	o-	Ba rema mohlare./ Ba a <b>o</b> rema.
4	Me-	e-	Ba rwele merwalo./ Ba <b>e</b> rwele.
5	Le-	Le-	O robile lebati./ O <b>le</b> robile.
6	Ma-	a-	Ba thubile maboto./ Ba <b>a</b> thubile.
7	Se-	Se-	O nwele sehlaré./ O <b>se</b> nwele.
8	Di-	di	Ba swere dilepe./ Ba <b>di</b> swere.
9	N-	e-	Ba hlaba nku./ Ba a <b>e</b> hlaba.
10	Di-	di-	Ba rekile dinku./ Ba <b>di</b> rekile.
14	Bo-	Bo-	Ba rata bohodu./ Ba a <b>bo</b> rata.
15	Go	Go-	Ba rata gosebana./ Ba <b>go</b> rata.
16	Fa-	Go-	Re epa fase./ Re a <b>go</b> epa
17	Go-	Go-	Ba lebelela godimo./ Ba <b>go</b> lebelela.
18	Mo-	Go-	Ba namela ka morago./ Ba <b>go</b> namela.

The objectival agreement of the 1<sup>st</sup> person singular involves phonological changes when it is used before certain consonants such as t, p, kg, and k, and that the objectival concords become a nasal consonant **n** or **m**. The same view is echoed by Paulos et al. (1994:175).

The objectival agreement for noun class 1 is derived from a number of phonological changes, such as the assimilation of certain consonants which are pronounced at the same places of articulation as others that assimilate them. These include bilabial and nasal sounds such as (m), (b), (n) in which for example the following occurs.

Consonant (m), which is articulated at the same place as (b), has the power to assimilate bilabial (b) so that it is pronounced exactly the same as (m). This phonological change in language, influences the objectival agreement. When the first person indicates that his/her action of seeing for example, falls on the person in noun class 1 (motho), the (m) phonologically changes (b), so that it is pronounced more or less the same as (m). Let us consider the following examples:

- 197.a. Ke **bona** motho. (I see a human being.)
- b. Ke a **mo bona**. (I see the him.)
- c. Ke a **mmona**. (I see him.)

When the sound changes because the first person wishes to indicate that the action of the verb, falls on him or her, the nasal **n-** or **m-** is prefixed to the verb to take the place of the bilabial **b-**, as in example 197.c in which the nasal **m-** assimilates the **b-**. The nasal sound **n**, (m) or (ng), is added before the verb root as a prefix of the verb and certain consonants such (r), (b), (d), (f), etc change phonologically to form new sounds which become objectival agreements in those sentences. Examples:

- 198.a. Matome o **bitša** nna ka leina.
- b. Matome o a **mmitša** ka leina.
- c. Matome o **mpitša** ka leina. (b>mp)  
(Matome is calling me by my name.)

- 199.a. Mma o fora nna. (Mother is lying for me.)  
 b. Mma o a nfora. (Mother is lying on me.)  
 c. Mma o a mphora. (Mother is lying for me.) f>mp
- 200.a. Mpša e loma nna. (The dog bites me.)  
 b. Mpša e a nloma. (The dog is bites me.)  
 c. Mpša e a ntoma ( l > nt)

In sentence 198a, the sound **b-** for **bitša** is bilabial. The word **bitša** is changed to **mmitša**. The sound **b-** is influenced by **m-**, because both sounds are articulated at the same places, and **b-** becomes **mm-** which is the agreement morpheme for the 2<sup>nd</sup> person singular. Sounds **b-** and **m-** turn to sound more or less the same because they are produced from the same organ. In sentence 198b, the sound **mm-** changes to **mp-**, which forms the agreement morpheme for 1<sup>st</sup> person singular.

In sentence 199a, a labio-dental sound **f-** for **fora**, is prefixed with **n-** to form **nfora**. This word is further changed to **mphora** when the **n-** is changed to **m-** and **f-** is plosivated to **ph-**. This forms the objectival agreement for the first person singular as it appears in sentence 199c above. Sound **f-** changes to **ph-**.

In sentences 200 for example, the sound **l-** for **loma** is prefixed with a nasal sound **n-** as is in example 200b, to bring agreement of the first person singular. The **l-** sound is changed to the **t-** to form **ntoma**. The nasal sound (**m**) and (**n**) serve as objectival agreements for the first person singular in the examples above.

Lombard et al (1985:104) support Paulos et al. (1994) on the idea that the prefix of class 9 (N-) is the objectival concord of the 1<sup>st</sup> person singular (n-) and it causes the strengthening of the first consonant of the verbal root, but the nasal, is never deleted. Paulos et al (1994:168) complement Lombard's argument by saying that the first person has two forms namely the **ke** and **n-**. When the first person pronoun (**nna**) is deleted, the verbal root is preceded by the nasal, which becomes objectival agreement for the first person. Below are a few examples of the objectival agreement of the 1<sup>st</sup> person singular.

**-m-** before the bilabial consonants.

- 201.a. O tlo **b**ona nna. (He will see me.)  
b. O tlo **m**pona. (He will see me.)
- 202.a. Le makatša nna. (you amaze I.)  
b. Le a **m**makatša. (You make me amaze.)

**-n/ng** before the velar consonant.

- 203.a. Ga o kwe nna?  
b. Ga o **n**kwe ?  
(Do not you understand me?)
- 204.a. O agela nna? (He builds for me?)  
b. O a **n**kagela?  
(Does he builds for me?)

It is important to note that the examples 201a, 202a, 203a, and 204a above do not use objectival agreement. When the pronoun **nna** (me) for the first person is omitted, the nasals **m-** or **n-** forms the prefix of the verb and morphologically becomes the objectival agreement, as in sentences 201b, 202b, 203b and 204b above.

The nasal consonant which is placed before the verbal root indicates that the action of the verb falls on object noun, in this case being the first person singular **nna** (me).

#### 4.3.1.5. *The objectival agreement for the first person plural*

The objectival agreement for the first person plural takes the **re** or **ra** for this class. In this case the agreement refers to more than one individuals who occupies the position of the first person plural. The following are some examples:

205.a. Ba bolela le rena. (They speak with us.)

b. Ba a re bolediša. (They cause us to speak.)

206.a. Tate o rapela le rena. (My father is praying with us.)

b. Tate o a re rapediša. (Father is causing us to pray or assisting us to pray.)

The use of the agreement **re / ra** in the above examples bring morphological changes in the verbal root in each sentence mentioned. The changes that can be observed are that when the pronoun for the first person plural **rena** (we) is omitted, the objectival agreement **re**, is used in its place, while the verbal root is suffixed with the causative terminative **-iša**, and the last consonant of the verb stem changes to a flap sound (**d**).

#### 4.3.1.6. Subjectival agreement for class noun 1a and 2a

##### A. Noun Class 1a

Noun class 1a is for personal names. It represents names of particular persons in their singular form, such as Malose, Mokgadi, Matome, etc.

Unlike other classes, this class does not have a noun prefix as it accommodates names with different prefixes such as **Ra-**, **Le-**, **Ma-**, etc. In Northern Sotho, the subjectival agreement for this class remains **o** in most cases. Below are some examples:

207. Ratau **o** nyetše mosadi.  
( Ratau got married.)
208. Mokgadi **o** tšweletše dithutong.  
( Mokgadi passed in the examinations.)
209. Lesiba **o** swaretšwe bohodu.  
(Matome is arrested for theft.)

In noun class 1a above, all proper names take the agreement **o**. It is evident that all singular personal nouns in Northern Sotho take a singular agreement **o**.

##### B. Noun Class 2a

Most nouns from this class are personal names. The prefix for this class is **Bo-** while the concordial agreement for this class is **ba**. This class forms the plural form for class 1a. The concordial agreement **ba** shares the same morphological features with its prefix.

To constitute plurality for this class, one must prefix personal nouns with **Bo-**. The nouns morphologically become plural. Let us look at a few examples.

210. BoMolatelo **ba** rekile dikoloi.  
(Molatelo and company have bought cars.)
211. BoLesiba **ba** rutegile.  
(Lesiba and company are educated.)
212. BoMatome **ba** šoma ditoropong.  
(Matome and friends are working in towns.)

It is noted that the subjectival agreement for noun class **2a** is **ba**. This is the same as the plural form in class 2. The major reason for the subjectival agreement for this class to remain **ba** is that it is a plural lexical morpheme, and it refers to a group of people as is the case in noun class 2.

#### 4.3.1.7. *Objectival agreement for Noun class 1a and 2a*

##### **A. Noun class 1a**

The object concord of class **1a** represents personal nouns in their singular form. The agreement is influenced by the change in the verbal root when the bilabial **m-** or **mo-** is prefixed to the verb to give the object noun an object concord. Below are a few examples:



Column A	Column B
213. Mokgadi o bone <b>Manana</b> . (Mokgadi saw Manana. )	Mokgadi o <b>mmone</b> . (Mokgadi saw her.)
214. Re swere <b>Malose</b> . (We arrested Malose.)	Re <b>mo</b> swere. (We arrested him.)
215. Lesiba o bitša <b>Sello</b> . (Lesiba is calling Sello.)	Lesiba o a <b>mmitša</b> . (Lesiba is calling him.)

In the above examples, the nouns **Manana**, **Malose** and **Sello** are seen appearing in constructions in column A. In column B sentences they are represented by object concords such as **m-**, **mo**, and **m-** respectively. If it happens that the object is known to both the speaker and the listener, then the noun might be deleted, and the object concord used in its position as evidenced in column B above.

#### A. Noun Class 2a

The objectival concord for the noun class **2a** differs greatly from objectival concord of the noun class **1a**. The nouns from noun class **2a** which represent plural nouns, take **Bo-** as their prefix, as witnessed in earlier paragraphs. Their objectival agreement is **ba-**. Let us consider the following examples below:

Column A	Column B
216. Re bone <b>bo</b> Matome. (We saw Matome and company.)	Re <b>ba</b> bone. (We saw them.)
217. Ke rata <b>bo</b> morutišigadi. (I love the lady teacher.)	Ke a <b>ba</b> rata. (I love her.)

In the above examples, the objectival concords **ba** in column B have two different meanings. The agreement **ba-** appearing in column B sentence 216, has a meaning of plurality. In this case it means that the speaker and his friends saw a group of people among whom there is a person called Matome.

In sentence 217, column B, the agreement **ba-** unlike in example 216, displays a honorific meaning. The speaker uses the plural agreement referring to a single person **morutišigadi** (lady teacher), so as to show respect to the person because of her status. What is interesting about this is that when sentences are written in isolation like they appear in column B above, they generalise and do not carry a complete meaning. One may never know to whom such sentences refer unless the referent is known to both the addresser and the addressee.

#### 4.3.1.8. *Demonstratives*

In this sub-section attention will be paid to the use of demonstratives as regards agreement in Northern Sotho constructions. According to Lombard et al. (1984:87), demonstratives which are also known as indicating pronouns are subdivided into positions on the grounds of relative distance from the speaker to the object referred.

Lombard et al. (1984:153) further point out that morphologically demonstratives consist of the concordial agreement morpheme as the prefix **l-** in **le**, for first distance position in class 5. To form the second distance position, the suffix **-o** is added to **le** to form **leo**, while the **la-** is added to **le** to form **lela**, for the third distance position. To add to the view of Lombard et al.(1984), Ziervogel (1972:51) states that demonstratives may be derived from the subject concord plus the vowels such as **-e** and **o**, to the first person and that the demonstrative for the second position in noun class 5 is **-leo**. **La** is added to **le** to form **lela** for the third distance position.

Like Lombard et al.(1985), Ziervogel (1972:52), identifies three series of demonstratives representing the basic distances or positions with reference to the speaker. The rule expresses three positions such as noun class 1 below for example.

- |            |      |  |
|------------|------|--|
| Position 1 | 218. | Mosadi yo ke mma.<br>(This lady is my mother.)           |
| Position 2 | 219. | Mosadi yoo ke mma.<br>(That lady is my mother.)          |
| Position 3 | 220. | Mosadi yola ke mma.<br>( That lady yonder is my mother.) |

Below is a table to represent 3 different basic demonstrative positions according to noun classes. The table includes class prefix, pronoun word, the root, the suffix, and the three positions (i.e 1, 2, and 3 respectively.)

C.Prefix	P/Word	Concord	Root	Positions		
				1.	2.	3.
1.Mo-	yo	y-	-o	Motho <b>yo</b> ke tate.	Motho <b>yoo</b> ke tate.	Motho <b>yola</b> ke tate.
2.Ba-	ba	b-	-a	Batho <b>ba</b> ke bana.	Batho <b>bao</b> ke bana.	Batho <b>bala</b> ke bana.
3.Mo-	wo	w-	-o	More <b>wo</b> o omile.	More <b>woo</b> o omile.	More <b>wola</b> o omile.
4.Me-	ye	y-	-e	Mere <b>ye</b> ke mego.	Mere <b>yeo</b> ke mego	Mere <b>yela</b> ke mego.
5.Le-	le	l-	-e	Legae <b>le</b> ke laka.	Legae <b>leo</b> ke laka.	Legae <b>lela</b> ke laka.
6.Ma-	a	a-	-a	Mare <b>a</b> ke a mpya	Mare <b>ao</b> ke a mpya	Mare <b>ale</b> ke a mpya.
7.Se-	se	s-	-e	Sešebo <b>se</b> ke mae.	Sešebo <b>seo</b> ke mae	Sešebo <b>sela</b> ke mae.
8.Di-	tše	tš-	-e	Dinepe <b>tše</b> di mpe	Dinepe <b>tšeo</b> dimpe	Dinepe <b>tšela</b> di mpe.
9.N-	Ye-	y-	-e	Nku <b>ye</b> ke kgapa.	Nku <b>yeo</b> ke kgapa.	Nku <b>yela</b> ke kgapa.
10.Di-	Tš-	Tš-	-e	Dinku <b>tše</b> ke tšaka	Dinku <b>tšeo</b> ke tšaka.	Dinku <b>tšela</b> ke tšaka.
14.Bo-	bjo	Bj-	-o	Boloi <b>bjo</b> ke hlago	Boloi <b>bjoo</b> ke hlago.	Boloi <b>bjola</b> ke hlago.
15.Go-	mo	m-	-o	Go ja <b>mo</b> go bose.	Go ja <b>moo</b> go bose.	Goja <b>mola</b> go bose.
16.Fa-	fa	f-	-a	Fase <b>fa</b> go bothata.	Fase <b>fao</b> go bothata.	Fase <b>fala</b> go bothata.
17.Go-	-	-	-	-	-	-
18.Mo-	mo	m-	-o	Morago <b>mo</b> gobose	Morago <b>moo</b> gobose	Morago <b>mola</b> gobose

#### 4.3.1.9. Concordial elements and their class prefixes

In the above table, the agreement is indicated in the second column. Paulos et al. (1994:82) state that demonstratives are formed when vowels are added to the prefix of concordial elements which are derived from the class prefix of every noun class. In the case of classes 1, 4, and 9, the semi-vowel **y**, which is formed by the coalescence of vowels **a** and **e**, functions as a concordial element; whereas the semi-vowel **w** which is formed by the coalescence of vowels **a** and **o**, occurs as a semi-vowel in 3. In noun class 6, the concordial element **a** has coalesced with the root **a**.

In the case of classes 8, 10, and 14, the concordial element which originally was **di-** for classes 8 and 10 and **b-** for class 14, have been palatalised to **tš-** and **bj-** respectively.

In most cases, the vowel which functions as the root bears a resemblance to the vowel of the class prefix of the same class to which the concordial element belongs, as can be seen in classes 1 to 7 as well as in 17 and 18. In short this means that if the vowel of the class prefix is **o**, then the vowel of the concordial element of the same class will also be **o**. If the vowel of the class prefix is **e**, the vowel of the concordial element of the same class will be **e** as well. This explanation however, does not fully bracket concordial elements of some classes such as 8, 9, and 10 indicated in the above paragraph.

The table above represents demonstratives in three different positions. The concordial agreement morphemes for the demonstratives have relatively more or less similar characteristics as their noun prefixes of the class to which they belong. Let us consider the following examples:

- |      |   |                            |
|------|---|----------------------------|
| 221. | Lesogana <b>leno</b> ke la ka.<br>(This gentleman is mine.)   | (1 <sup>st</sup> position) |
| 222. | Lesogana <b>leo</b> ke la ka.<br>(That gentleman is mine.)    | (2 <sup>nd</sup> position) |
| 223. | Lesogana <b>lela</b> ke la ka.<br>(Yonder gentleman is mine.) | (3 <sup>rd</sup> position) |

The above examples show some grammatical relationship between noun prefixes and the demonstratives of that class to which the demonstrative belongs, in terms of morphological structure and meaning. The demonstrative **le/leno** takes the form of the noun prefix for class 5, and the meaning also refers to a noun that belongs to class 5 in terms of grouping and relevancy. The root of the demonstrative pronouns changes at times depending on the position of the referent. Lombard et al. (1984:89) indicate that classes 16, 17, and 18, (locatives) make use of demonstratives as their agreement. These demonstratives are similar to other concordial elements. The demonstratives in these classes indicate the locatives in terms of position and relative distances. Examples:

224. Felo **fa** go nkgā nama. ( Class 16) : Position 1.  
(This place smells the meat.)
225. Fase **fao** go bothata. ( Class 16) : Position 2.  
(Down there is hard.)
226. Fase **fale** go tletše madi. ( Class 16 : Position 3.  
(Down yonder is full of blood.)
227. Morago **mo** go a tonya. ( Class 18 : Position 1.  
(At the back it is cold.)
228. Morago **moo** ga o tonye. ( Class 18 : Position 2.  
(At back there is not cold.)

229. Morago **mola** go borutho. Class 18: Position 3.  
(At the back yonder is warm.)
230. Godimo **mo** ga o boifiše. Class 17: Position 1.  
(At the top here is no frightening.)
231. Godimo **moo** ga o boifiše. Class 17 : Position 2.  
(At the top there is not frightening.)
232. Godimo **mola** go a boifiša. Class 17: Position 3.  
(Up yonder is frightening.)

The sentences 224 to 232 above show that the demonstratives for classes 16, 17, and 18, consist of the concordial elements which are derived from class prefixes, and the vowel root which looks the same as the vowel of the prefix of that class to which the demonstrative belongs. The second and the third distance positions, are suffixed with **o** vowel and **la / le**, respectively, as a way of differentiating the two distances in terms of positions.

#### 4.4. THE DISTRIBUTION OF AGREEMENT MORPHEMES

In this section, the focus will be on the distribution of agreement in Northern Sotho constructions, and the possible meanings that could be brought about by such constructions.

#### 4.4.1. Pronouns

Different types of pronouns will be discussed under this section. Among other pronouns that occur in Northern Sotho, the following three important ones will be given more preference. Along with what Freebora (1995:95) says about a pronoun, he defines a pronoun as a word which stands for another word. A pronoun is a word whose function is to stand for a noun. Adding to Freebora's definition, Matthews (1994:355) maintains that pronouns can function as a whole noun phrase, for example in being a subject or an object of a clause, such as the following:

- 233.a.     **Rakgwale** o bolela ka Motimele.  
          (Rakgale is speaking about Motimela.)
- b.     **Yena** o bolela ka Motimele.  
          (He is speaking about Motimele.)

In sentence 233a, two names (Rakgwale and Motimele ) have being used, but in sentence 233b only one name (Motimele) was used. In the place of Rakgwale, a pronoun **Yena** was used. This pronoun stands for the name. This can at times pose problems to those people who do not know the referent, but to those who already know the referent, it is easy to comprehend.

Lombard et al. (1984:84), in support of the above definitions on pronoun, profoundly define a pronoun as a word category that displays morphological characteristics of concordial morpheme and root or-stem.



It is important also to note that a pronoun always remains useful in language standing for names or replacing names or nouns in a sentence where the speaker does not want to mention the name repeatedly in every sentence, but instead uses the pronoun. This study will discuss three types of pronouns, viz;

- (a) Absolute pronoun.
- (b) Possessive pronoun.
- (c) Quantitative pronoun.

#### 4.4.1.1. *Absolute pronoun*

According to Ziervoegel (1979:47), an absolute pronoun is one which, takes the position of a noun as a subject or an object of the sentence. Adding to Ziervoegel's idea, Louwrens (1994:99) states that "... the occurrence of the absolute pronoun results from the replacement of the noun ...". Each class of nouns has a corresponding absolute pronoun which consists of a pronoun root plus **-o-** or **-e-** followed by the suffix **-na**. Below is a table of noun classes to represent absolute pronouns:

<b>Persons</b>	<b>Absolute pronouns</b>	<b>Concordial agreement</b>
<b>1<sup>st</sup> person Singular</b>	<b>-nna</b>	<b>- ke.</b>

234. **Nna ke** bolela le Mokgadi.  
(I speak to Mokgadi.)

**1<sup>st</sup> person plural                    -rena    - re.**

235.        **Rena re bone mašole.**  
              (We saw the soldiers.)

**2<sup>nd</sup> person singular                    -wena    -o.**

236.        **Wena o hlola mathata.**  
              (You are causing problems.)

**2<sup>nd</sup> person plural                    -lena    - le**

237.        **Lena le bana ba sekolo.**  
              (You are school children.)

<b>Noun class prefix.</b>	<b>Absolute pronoun</b>	<b>Concordial agreement.</b>
1.Mo-	Yena	Ye-
2.Ba-	bona	Bo-
3.Mo-	wona	Wo-
4.Me-	yona	Yo-
5.Le-	lona	Le-
6.Ma-	wona	Wo-
7.Se-	Sona	Se-
8.Di-	tšona	Tšo-
9.N-	yona	Yo-
10.Di-	tšona	Tšo-
14.Bo-	bjona	Bjo-
15.Go-	gona	Go-
16.Fa-	gona	Go-
17.Go-	gona	Go-
18.Mo-	gona	Go-

In the above table, it is realised that the concordial morphemes grammatically and semantically agree with the absolute pronoun in each case.

The prefix for the first and second singular and plural persons show a clear correspondence with the concordial agreement. Morphologically, the absolute pronoun consists of the concordial morpheme as the prefix.

The concordial morpheme of the other classes is in agreement with its subject concord. In the case of persons there is also an agreement between the pronominal concordial morpheme and the subject concord. What this means is that the concordial morpheme of the absolute pronoun is clearly in agreement with the class prefix of the class concerned.

In 1<sup>st</sup> person singular, the pronoun is **nna** and the concordial agreement is **ke**. The absolute pronoun in this case cannot function alone without employing the concordial agreement **ke**. In the case of the first person plural, the absolute pronoun is **rena** and the concordial agreement is **re**.

The concordial agreement for the 1<sup>st</sup> person plural has the same morphological features as the absolute pronoun in terms the vowel of the **e**, in the pronoun. The absolute pronoun for the 2<sup>nd</sup> person singular remains **yena**, and the concordial agreement **o** for the 1<sup>st</sup> person singular shares the same morphological features with the **o** of the noun prefix of class noun 1. The concordial agreement for the 2<sup>nd</sup> person plural has the same morphological features as the prefix of the absolute pronoun **le-**. Let us consider the following examples:

- |      |  |                           |
|------|--|---------------------------|
| 238. | <b>Nna ke</b> sepela bošego.<br>(I walk during the night.)               | (First person singular.)  |
| 239. | <b>Rena re</b> sepela bošego.<br>(We are walking during the night.)      | (First person plural.)    |
| 240. | <b>Wena o</b> sepela le mahodu.<br>(You are accompany with the thieves.) | (Second person singular.) |



<b>PERSONS.</b>	<b>CONCORDIAL AGREEMENT</b>	<b>EXAMPLES .</b>
1 <sup>st</sup> person sing.	Ya ka	O bolaile mpša ya <b>ka</b> .
1 <sup>st</sup> person plur.	Ya rena	Ba bone koloi ya <b>rena</b> .
2 <sup>nd</sup> person sing.	Ya gago	Ke nku ya <b>gago</b> ye.
2 <sup>nd</sup> person plur.	Ya lena	Re rwele nama ya <b>lena</b> .
<b>CLASS PREFIX</b>	<b>CONCORDIAL AGREEMENT.</b>	<b>EXAMPLES.</b>
1. Mo-	Wa-	Mosima ke mosadi <b>waka</b> .
2. Ba-	Ba-	Ke bana <b>ba</b> mosadi wa Lesiba.
3. Mo-	wa	Morwa <b>wa</b> Maepa o nyetše.
4. Me-	ya	Metse ya toropo e na le mabone.
5. Le-	la	Leoto <b>la</b> malome le robegile.
6. Ma-	A	Maoto <b>a</b> ka a rurugile.
7. Se-	sa	Sejo <b>sa</b> setšo se a khuriša.
8. Di-	tša	Ditsebe <b>tša</b> kgomo ke tše kgolo.
9. N-	ya	Kgoši ya gešo e hlokofetše.
10.Di-	tša	Dinku <b>tša</b> ka ditimetše.
14.Bo-	bja	Bodulo <b>bja</b> nong ke thabeng.
15. Go-	go	Go bolela <b>ga</b> bona go sentše.
16. Fa-	ga	Fase <b>ga</b> moriti go na le motho.
17. Go-	ga	Godimo <b>ga</b> ntlo ga re namele.
18. Mo-	ga	Morago <b>ga</b> koloi go lerole.

The morphological structure of the possessive concordial morpheme is similar to those of the noun prefix of the class to which they belong, with the exception of classes 3,4,8, 9,and 10, in which the morphological structure of the consonant is different. Consider the following examples:

243.a.	Mohlare wohle o omile. (The whole tree is dry.)	Noun class 3
b.	Mehlare yohle e remilwe. (All the trees have been cut.)	Noun class 4
c.	Dithokgwa tšohle ke mašemo. (All the bushes are fields.)	Noun class 8
d.	Nku yohle ke ye ntsho. (The whole sheep is black.)	Noun class 9

In the table above, the concordial agreement in noun classes 1,2,3,4,5,7,8 to 18 consists of the concord and the root. The concord is the consonant that forms the prefix of the concordial morpheme, and the root which forms the terminative of the concordial agreement. The terminative is, in most cases, the vowel **a** and the concordial prefix is the consonant which in some selected noun classes, take the form of the noun prefix, such as in classes 2,5,7,14,17 and 18. In other classes however, such as 1,3,4 and 9, the concordial prefixes are the semi-vowels such as **w** and **y**. The second part of the concord, consists of the terminative **-a** of which the concordial agreement is composed.

#### 4.4.1.3. *Quantitative Pronoun*

According to Lombard et al.(1984:90), quantitative pronouns are morphologically constituents of the concordial morpheme and the prefix of that class. The prefix of the concordial agreement looks more or less the same as the prefix of that class.

Ziervoegel (1979:61) supports Lombard et al.'s (1984) argument by saying that concordial morphemes relate to the class prefix of the class to which they belong.

PREFIX	PRONOUN WORD	CONCORD	EXAMPLES.
1. Mo-	yohle	-	Re tšeere monna yohle.
2. Ba-	bohle	b-	Ba biditye banna bohle.
3. Mo-	wohle	w-	Ba remile mohlare wohle.
4. Me-	yohle	y-	Mehlare yohle e remilwe.
5. Le-	lohle	l-	Lefelo lohle le tletše meetse.
6. Ma-	ohle	a-	Mafsika ohle a tletše madi.
7. Se-	sohle	s-	Sehlare sohle ke sa mala.
8. Di-	tšohle	Tš-	Dihlare tšohle ke medu.
9. N-	yohle	y-	Nku yohle ke ye tšhweu
10. Di-	tšohle	tš-	Dinku tšohle ke tšaka.
14. Bo-	bjohle	Bj-	Bosehla bjohle ke bja lerole.
15. Go-	gohle	g-	Go ja gohle ke bohodu.
16. Fa-	gohle	g-	Fase gohle ke madi.
17. Go-	gohle.	g-	Godimo gohle ke maru.
18. Mo-	gohle	g-	Morago gohle ke magomotša.

Let us take a few examples to see how concordial agreement matches noun prefixes of the class to which they belong.

- 244.a. Batho bohle ke badumedi.  
(All the people are believers.)



- b.           **Sehlare sohle se omile.**  
              (The whole tree is dry.)
  
- c.           **Godimo gohle ke maru fela**  
              (The whole atmosphere is overcast.)

The concordial agreement are in each case sharing the same morphological structure with their noun prefix. This evidence is realised in the following classes: 2, 5, 8, 10, 14, 15, and 17 for example, in which the concordial morphemes are exactly the same as the consonant of the noun prefix of the pronoun to which it belongs.

#### **4.5. Agreement by proximity**

In this section attention will be given to the agreement obtained when certain nouns in the sentence are so close to the verb to influence the agreement than nouns which are grammatically located far from the verb in the sentence to influence the verb but fail to do so, such that the noun which is very close to the verb puts more influence to the verb than nouns which are regarded to be the subject of the sentence. Therefore, those nouns which are grammatically located close to the verb have the advantage to change the agreement from being either plural to singular, depending whether they themselves are singular, or plural.

Certain grammatical constructions may provide complications, as Bartley (1996:3) puts it. Sometimes the noun that is adjacent to the verb can exert more influence to the verb and change its original meaning than the noun which is far from the verb.

In other words, those nouns which are originally subjects of the sentence may lose the advantage of influencing the sentence to be in the singular or plural form to the noun which is closer to the verb. Let us consider the following examples:

- 245.a. Ke banna goba Matome yo a swerego lehodu.  
(It is the men or Matome who caught the thief.)
- b. Magareng ga bašemane le Mary ke may yo a swerwego?  
(Between the boys and Mary who is arrested?)
- c. E ka ba Malose goba banna bao ba gapilego sefoka.  
(It might be Malose or the men who won the prize.)

In sentence 245.a for example, the noun **banna** (the men) seems to be the main subject of the sentence than the noun **Matome**, but for the fact that the noun **Matome** is closer to the verb than **banna** (the men), the noun **Matome** influences the verb to take a singular agreement, **yo**. According to the rule of grammar, the agreement for the noun **banna** was supposed to be **ba** for noun class 2, but for the reason that the noun **Matome**, which is a singular noun is too close to the verb, **Matome** exerts more influence to the verb, thus bringing the singular agreement **yo**.

The same occurs in sentence 245.b in which the singular subject **Mary**, which is closer to the verb, has an influence to the verb than the subject **bašemane** which is not at a closer proximity to the verb than the noun **Mary**. This is also observed in example 245.c where the plural subject **banna** (the men), which is closer to the verb, is exerting more influence to the verb to bring about a plural agreement **ba**, than the subject **Malose**, which is singular and is lying far from the verb to be able to influence the agreement to take a singular form in that sentence.

#### 4.5. CONCLUSION

The use of agreement in language grammar is indispensable and its correct use cannot be over-emphasised. The form of agreement as presented, shows that there is an inseparable correlation between the subject of the sentence and the concordial agreement. Most agreements share similar morphological features with the prefixes of their noun classes. It was also found out that noun classes play a major role in determining the form, usage and meaning of the agreement for all nouns. Subjectival and objectival agreements have a role to play in bringing grammatical relationship between words and nouns in the sentences. It was also indicated that demonstratives such as pronouns, have a role to form agreement between words in a sentence. One most interesting aspect that leaves a mark in this study is that certain words in construction have the ability to govern others. Inflection can govern the NPs, and VPs also govern the NPs or their complements.

It was also realised that pronouns in language have the potentiality to generate agreement in construction, as was seen in absolute, quantitative and possessive pronouns. It was also found out that agreement may be influenced by nouns that are close to the verb than those nouns which are far away from the verb in the sentence. If, for example, a plural noun is written close to the verb in the sentence and a singular noun is written far away from the verb in the same sentence, this noun, which is close to the verb will have a profound influence on the agreement of that noun than the one which is far away from the verb.

## CHAPTER 5

### 5.1. CONCLUSION

The objective of this research was to examine agreement in Northern Sotho construction, and the different ways in which it can be used in a sentence to bring different meanings. In order to achieve the aim, views of different scholars of African Languages such as Lombard et al (1984), Paulos et al (1994), Louwrens (1991), Kgware (1975), Ziervoegel (1972 and 1979), Du Plessis and Madadzhe (1999) and scholars of English were consulted to accomplish this study.

Some non-Northern Sotho speakers at times use the language without following correct grammatical rules, something that results in misunderstanding and conflicts between Northern Sotho speakers and those who learn to speak the language as was seen in example 1.

It was also found that some speakers of the language use agreement for noun class 9 to address human beings as if they are objects. By so doing they are degrading the dignity of a human being as illustrated in example 2.

It was also realised that agreement in Northern Sotho is primarily linked to noun classes, as illustrated in the table on page 20. Noun classes are a springfield of any sentence formation. As seen, concordial agreement can be sub-categorised into strong and weak concordial agreements based on the morphological structure of the noun prefixes. Strong concordial agreements are illustrated in examples 22, 23, and 24.

Those examples of agreement sharing similar characteristic features with their noun prefixes are regarded as strong concordial agreements. Such an agreement is indicated by examples 26, 27, and 28 among others. On the other hand, those examples of concordial agreement which do not share similar characteristics with their noun prefixes are called weak concordial agreement, and are illustrated in examples 56, 57, and 58 among others.

It was also discovered that concordial agreement can move from one position to the other in a sentence so as to bring different meanings in the sentence concerned as can be seen in examples 73 and 74.

Concordial agreement can, at times, appear without a noun phrase or a pronoun. This is indicated by examples 75, 76, and 77. Such constructions bring new meaning to the affected sentence. Meaning of plurality in the case of sentence 75 and meaning of singularity in sentences 76, and 77. The concordial agreement may also work with both the noun phrase and the pronoun, in this case to bring a meaning of emphasis as is in examples 81, 82, and 83.

One also realises that notional agreement has the ability to bring plural meaning to those sentences with plural agreement even if the noun phrase is in singular form. This is evident as it is illustrated in examples 101, 102, 103, and 104 among others. On the other hand, noun phrases which appear in plural form, may have a singular meaning because of a singular agreement appearing in the sentence concerned. This can be seen in examples such as 120, 121, 122, and 123 among others.

Notional agreement can also bring honorific meaning. This is clearly seen in constructions used to address elderly persons, respected people and strangers. See examples such as 138, 139, and 140.

At times agreement referring to objects and animals can be used to address people with unbecoming behaviours so as to show diminutive and derogative meanings as exemplified in sentences 163, 164, and 165. Agreement in noun classes of objects and animals such as class 7, 8, and 9 may be used to refer to people with special expertise. Good examples are those in sentences 169, 170, and 171.

It was further discovered that agreement in a sentence as part and parcel of an inflection has the ability to govern the noun phrase to the most left position of the sentence, as in examples 179, 180, and 181. The objectival agreement for noun class 2a is **ba** while the objectival agreement for the first person singular is **m-** as in examples 190, 191, and 198, 199, 200 respectively. Again it was discovered that the subjectival agreement for noun class 1a is **o** while the subjectival agreement for noun class 2a is **ba**. This can be seen in examples 207, 208, 209, and 210, 211, 212 respectively.

As regards demonstratives, it was found out that certain noun prefix in demonstratives share the same characteristic features with their concordial agreements such as those in noun class 5, 7, 8, 14, and 16, as can be seen in examples 218, 219, and 220.

It was further discovered that in pronouns, the concordial agreements have the same characteristic features with absolute, possessive, and quantitative pronouns. The terminative vowel **-a**, for almost all the pronouns, repeats itself on the noun prefix while the concordial morpheme in some cases changes to a semi-vowel **y-** and **w-** as can be seen in examples 233b and 240.

The prefix morphemes **m-** and **n-** for classes 1, 3, 4, and 9 change to the semi vowel **y-** and **w-** respectively. This situation is visible in examples 1, 3, 4, and 9 on the table and in sentences 243a, b, and d. On the other hand, those quantitative and possessive pronouns whose prefix do not undergo morphological change share the same morphological structure with the prefixes of the noun to which they belong, as in examples 244a, 244b, and 244c.

Another discovery worth mentioning is that of agreement by proximity. In this case agreement is influenced by nouns which are closer to the verb than those nouns which are far away from the verb in the sentence concerned. This is clearly seen in examples 245a, 245b, and 245c.

## 5.2. BIBLIOGRAPHY

- Bartley, Com. 1996. *A Practical and Authoritative Guide to Contemporary English*. U.S.A The American Press.
- Chokoe, S.J. 2000. *Linguistic Ambiguity in Northern Sotho: Saying the Unmeant*. Unpublished D. Litt Dissertation, JohannesburgRandAfrikaansUniversity
- Chomsky N. 1972. *Aspects of the theory of Syntax*. Massachusetti. London. Cambridge. The M.I.T. Press.
- Chomsky N. 1980. *Rules and representations*. Colombia University New York. Colombia University Press.
- Clark.C 1981. *An introduction to the history of English language*. Great Britain. London. Thornes Express.
- Cole, D.T. 1964. *Some features of Ganda Linguistic Structure*. Unpublished M.A. Dissertation, Johannesburg. South Africa. University of the Witwatersrand,
- Creswell, J.W. 1994. *Research Design*. London: Thousand Oaks sage.
- Crystal. 1997. *The Cambridge Encyclopaedia of language*, 2<sup>nd</sup> edition. New York: Cambridge University Press.



- De Vos, A.S. 1998. *Research at Grass Roots*. Pretoria. South Africa: J.L Van Schaik.
- DuPlessis, J.A and Madadzhe, R.N. 1999. *Venda Morphology: Communication in African Languages* Cape Town: University of Stellenbosch
- Fowler, F.W. 1990. *The concise Oxford Dictionary*. Oxford: Oxford University Press,
- Freebora D. 1995. *A course book in English Grammar*. England: MacMillan.
- George Leech and Jan Svartvic. 1994. *Dictionary of Current English*. Oxford: Oxford University Press.
- Godi, P.S. 2002. *Focus construction in Xitsonga*. Unpublished M.A. Dissertation. Polokwane, South Africa, University of the North
- Haegeman, L.M.V. 1985. *A Modern Course in English Syntax*. Cape Town: Groot Helm.
- Horny, A.S. 2000. *Oxford Advanced Learners Dictionary of Current English*. Oxford: Oxford University Press.
- Kgware, W.M. 1975. *The Predicative in Tswana*. Unpublished M.A. Dissertation. Polokwane, South Africa: University of the North.

- Kotze, A.E. 1993. *Northern Sotho Phonetic and Phonology*. Cape Town: Marius Lubbe.
- Lombard, D.P, Van Wyk, E.B. and Mokgokong, P.C. 1985. *Introduction to the Grammar of Northern Sotho*. Hartfield. Pretoria: J.L. Van Schaik.
- Louwrens, L.J. 1991. *Aspects of Northern Sotho Grammar*. Pretoria, South Africa: Via Afrika.
- Louwrens, L.J. 1995. *Northern Sotho Study Guide for NSE 202 X*. Pretoria, South Africa: University of South Africa.
- Mathews, P.H. 1981. *Syntax*. London: Cambridge University Press.
- Mathews, P.H. 1990. *Morphology*. London: Cambridge University Press.
- Mouton, J. and Marais, H.C. 1992. *Basic Concepts in the Methodology of the Social Science*. Pretoria, South Africa: Human Science Research Council.
- Nauman, W.L. 1997. *Social Research Methods: Quantitative and Qualitative Approaches*. New York: Library of publication Data.
- Nemukula, N.A. 2003. *Politeness in Tshivenda*. M.A. Dissertation Unpublished. Polokwane, South Africa: University of the North.

- Ntsundeni, E.M. 2002. *The aspects of Morpheme in Tshivenda*. M.A. Dissertation Unpublished. Polokwane, South Africa: University of the North.
- Poulos, G and Louwrens, L.J. 1994. *A Linguistic Analysis of Northern Sotho*. Pretoria South Africa: J.L Van Schaik.
- Praver, S.S. 1973. *Comparative Literary Studies*. London: Gerlad Duckworth & Co. Ltd.
- Regain, C.C. 1987. *The Comparative Methods*. Berkeley: University of California Press.
- Spencer, T. 1967. *Linguistics and Style*. Oxford: Oxford University Press.
- Thwala, N. 2003. *The Syntax of Multiply Subject Agreement in Bantu Root Clauses*. Johannesburg, South Africa: University of Witwatersrand.
- Vivian Ridler. 1971. *The Compact edition of the Oxford English Dictionary*. Oxford: Oxford University Press.
- Webster, A.M. 1989. *The Merriam-Webster Dictionary of English Usage*. Springfield. Massachusetts. Merriam-Webster.
- World Book Dictionary. 1992. *Volume A-K*. U.S.A. World Books.

Ziervogel, D.

1979. *A Handbook of the Northern Sotho Languages.*  
Pretoria, South Africa: J.L. Van Schaik.